

## INCASSI\_BUILT-IN PARTS

R99686

Parte incasso. / Built-in part.



Parte incasso per miscelatore monocomando doccia.

Built-in part for shower mixer.

Marchio / Brand ZUCCHETTI

Classe / Class INCAS

## INCASSI\_BUILT-IN PARTS

R99686

Finiture / Finishes



Cromo / Chrome

Note / Notes

## INCASSI\_BUILT-IN PARTS

R99686

Disegno Complessivo / Overall Drawing

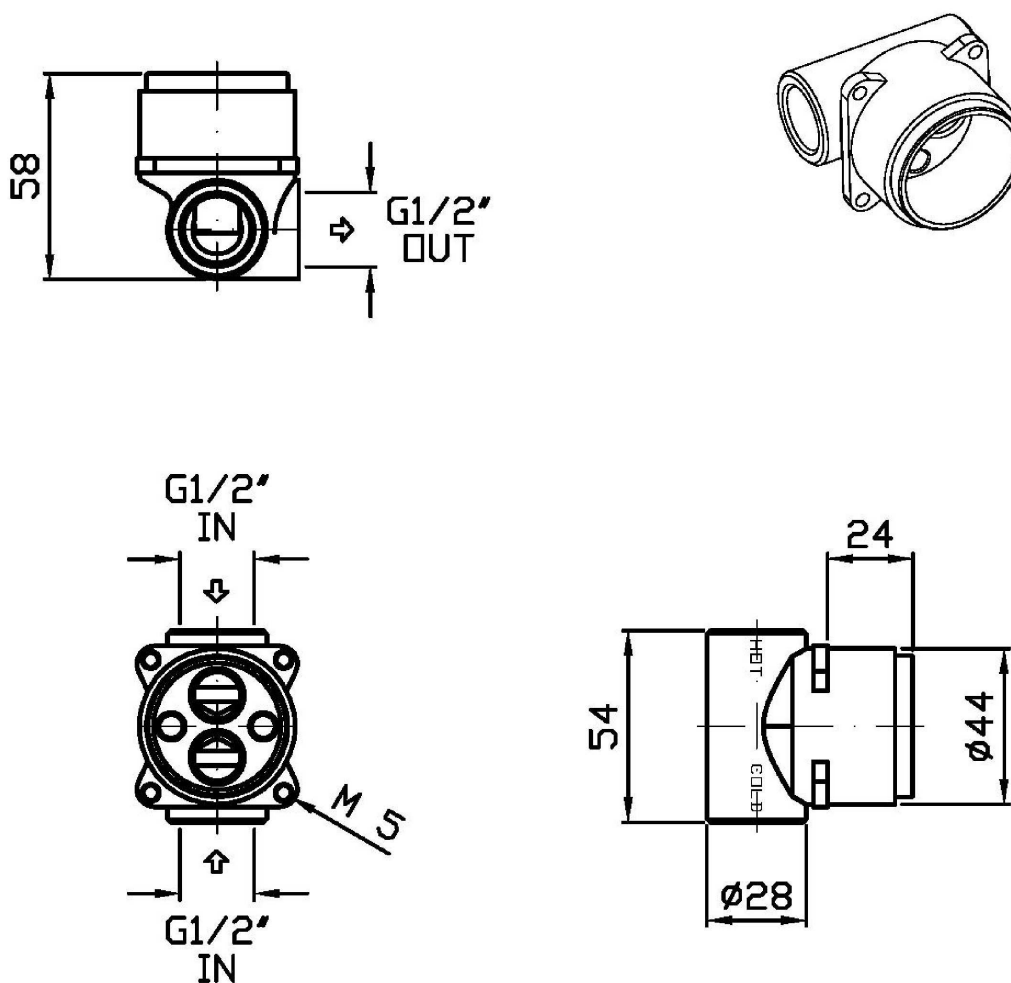

## INCASSI\_BUILT-IN PARTS

R99686

Portate / Flowrates (lt/min)

PRESSIONE PRESSURE	1 BAR	2 BAR	3 BAR	4 BAR	5 BAR
P1					
P2					
P3					
P4					
P5					

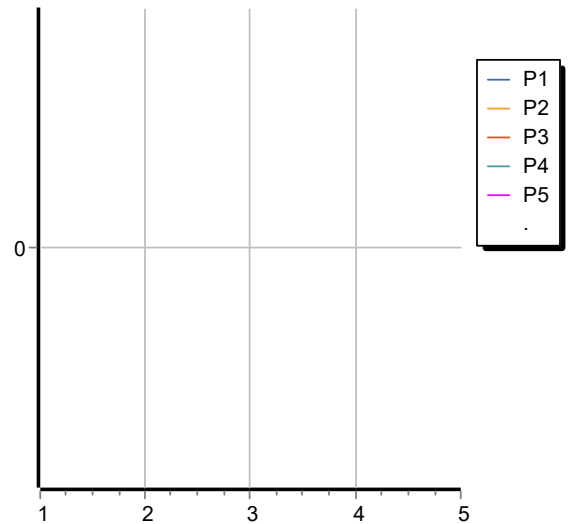

## INCASSI\_BUILT-IN PARTS

R99686

Pesi e Misure / Weights and Sizes

Peso ( Kg ) Weight ( lb )	0,65 ( Kg )	1,43 ( lb )
Volume test ( dc3 ) - ( in3 )	0,91 ( dc3 )	55,53 ( in3 )
h ( mm ) - ( in )	66,00 ( mm )	2,60 ( in )
L1 ( mm ) - ( in )	111,00 ( mm )	4,37 ( in )
L2 ( mm ) - ( in )	123,00 ( mm )	4,84 ( in )

