

INCASSI_BUILT-IN PARTS

R98662

Parte incasso. / Built-in part.



Parte incasso per miscelatore termostatico da 1/2" con deviatore a 2 vie.

Built-in part for 1/2" thermostatic mixer with 2 way diverter.

INCASSI_BUILT-IN PARTS

R98662

Finiture / Finishes

Note / Notes

INCASSI_BUILT-IN PARTS

R98662

Disegno Complessivo / Overall Drawing

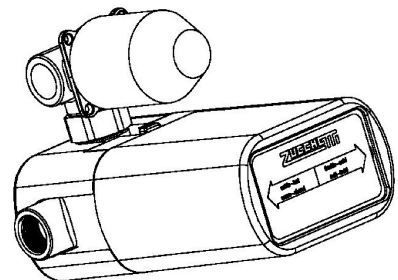
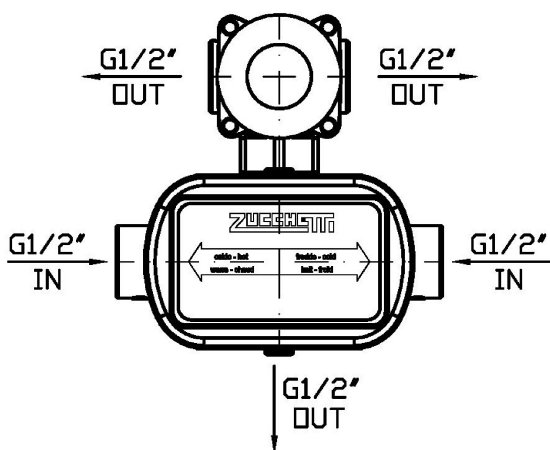
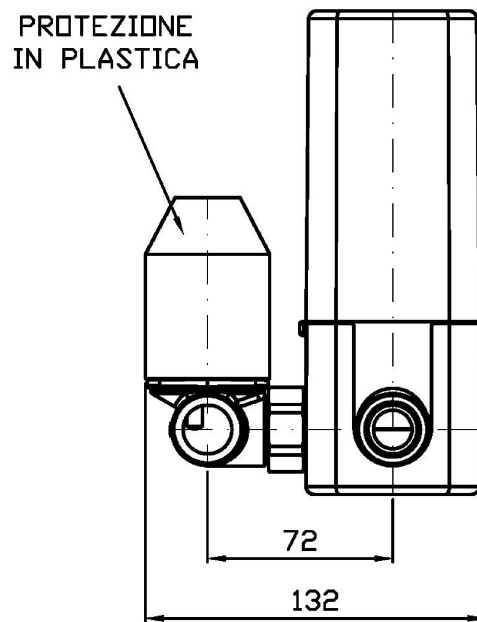
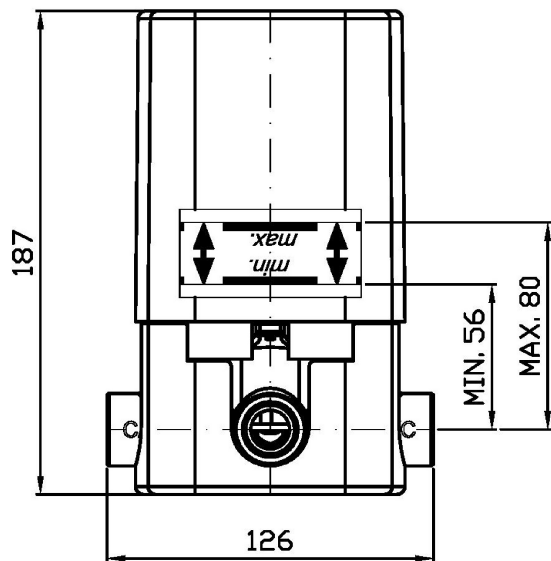

INCASSI_BUILT-IN PARTS

R98662

Pesi e Misure / Weights and Sizes

Peso (Kg) Weight (lb)	2,85 (Kg)	6,28 (lb)
Volume test (dc3) - (in3)	6,61 (dc3)	403,37 (in3)
h (mm) - (in)	143,00 (mm)	5,63 (in)
L1 (mm) - (in)	195,00 (mm)	7,68 (in)
L2 (mm) - (in)	237,00 (mm)	9,33 (in)

