

ZUCCHETTI.

Veloce

design Yabu Pushelberg

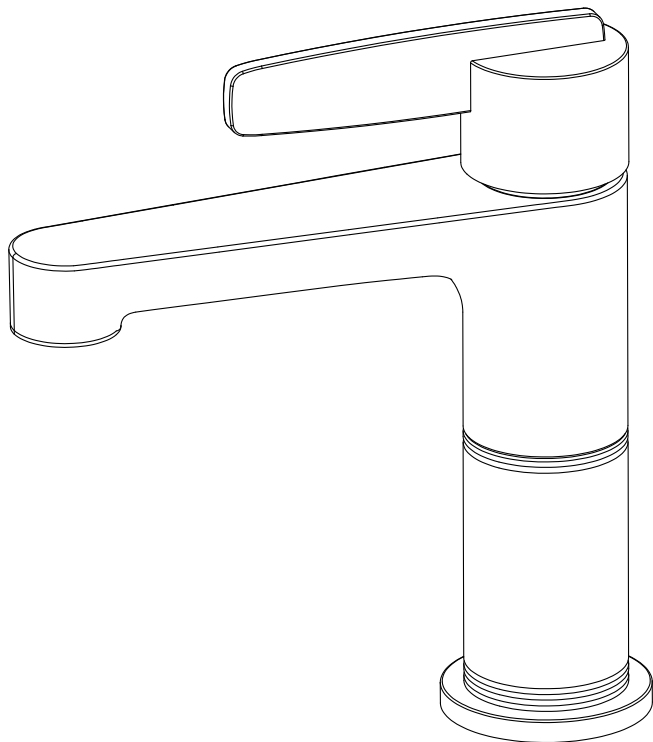

- I** Istruzioni per l'installazione della rubinetteria
- GB** Instructions for the installation of the faucets
- F** Instructions pour l'installation de la robinetterie
- D** Montageanleitungen zur installation der armaturen
- E** Instrucciones para la instalacion de la griferia
- RU** ИНСТРУКЦИИ ПО МОНТАЖУ СМЕСИТЕЛЬНОЙ АРМАТУРЫ
- PL** Instrukcje instalacji armatury

Index

Veloce collection

4

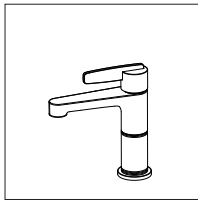

ZVE546

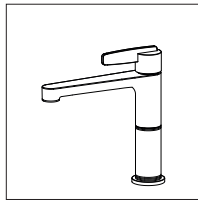

ZVE547

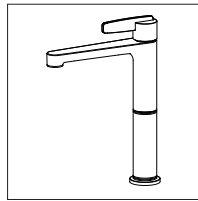

ZVE548

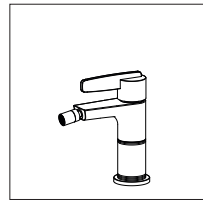

ZVE549

6

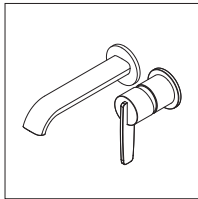

ZVE435

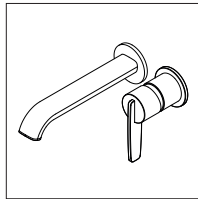

ZVE436

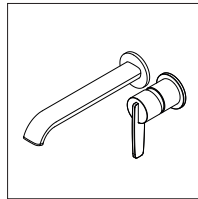

ZVE437

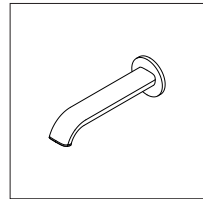

Z92266-Z92267-
Z92268

9

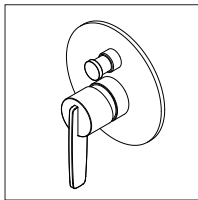

ZVE775

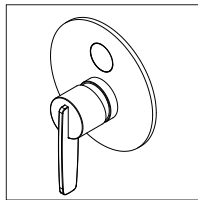

ZVE776

13

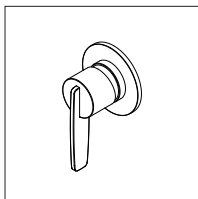

ZVE780

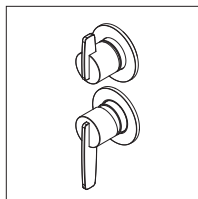

ZVE778

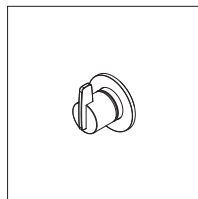

Z94633

15

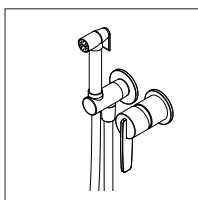

ZVE417

Installazione - Installation

ZVE546-ZVE547-ZVE548-ZVE549

Utensili necessari - Necessary tools

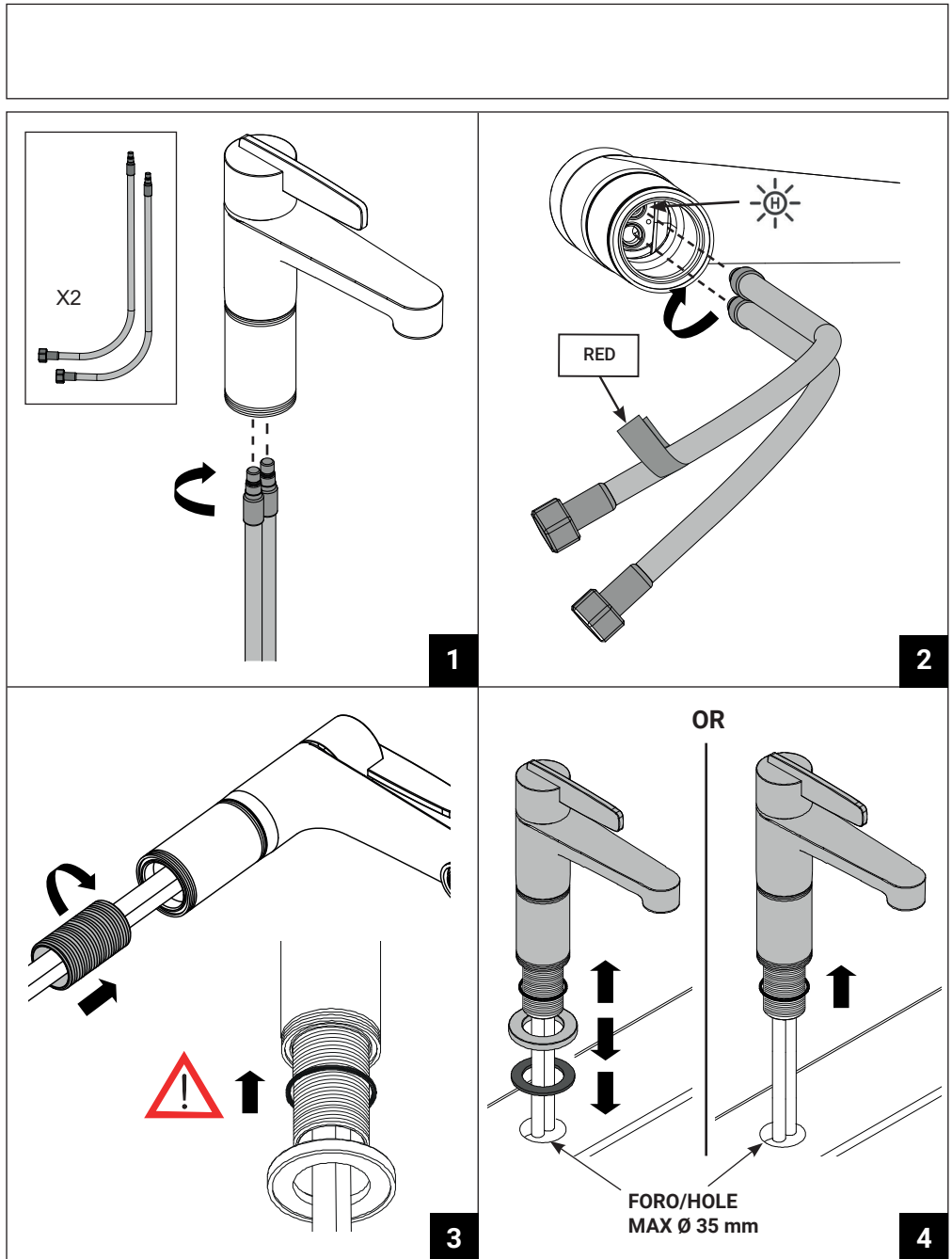

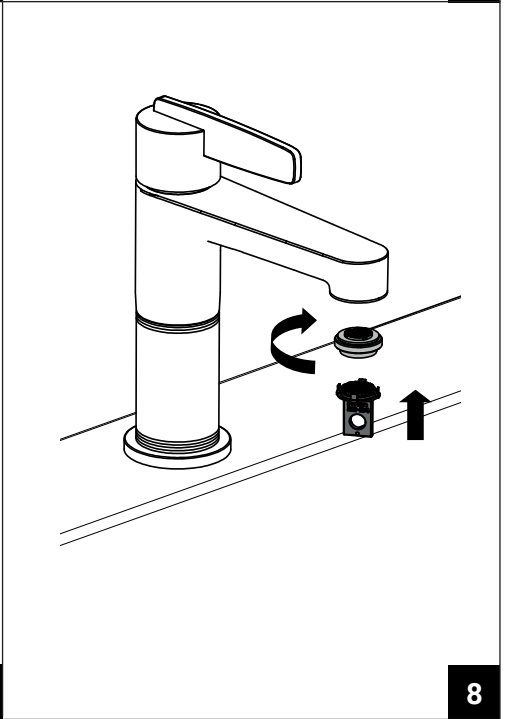
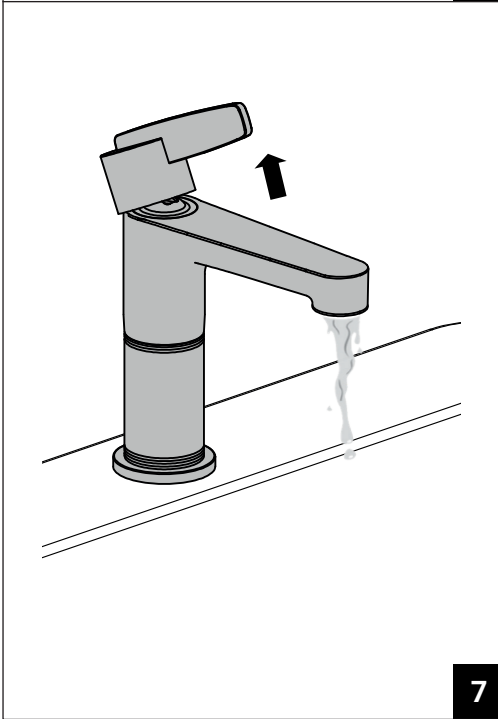
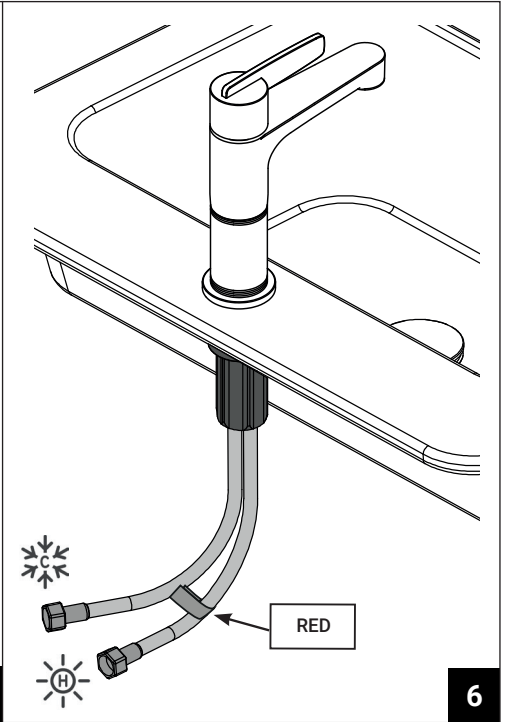
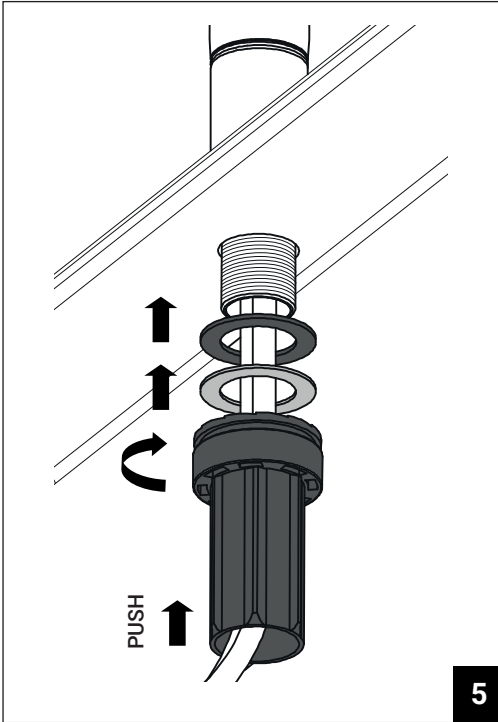

Installazione - Installation

ZVE435-ZVE436-ZVE437-Z92266-Z92267-Z92268

Utensili necessari - Necessary tools

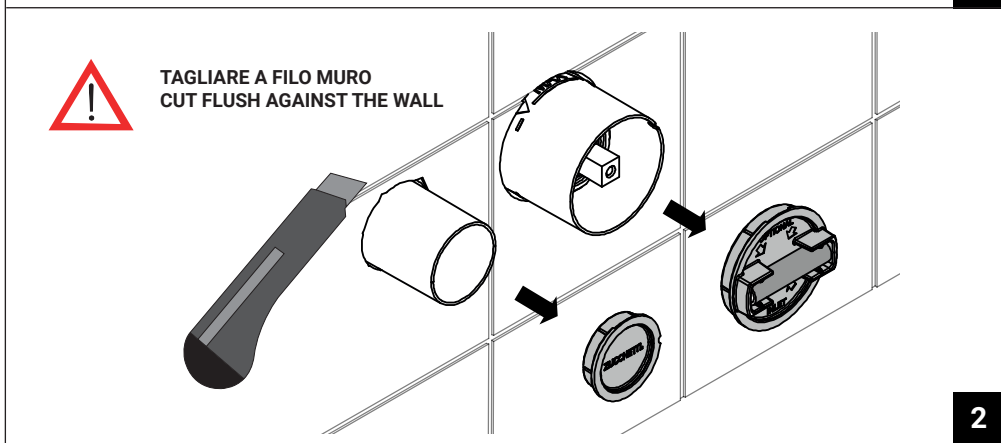
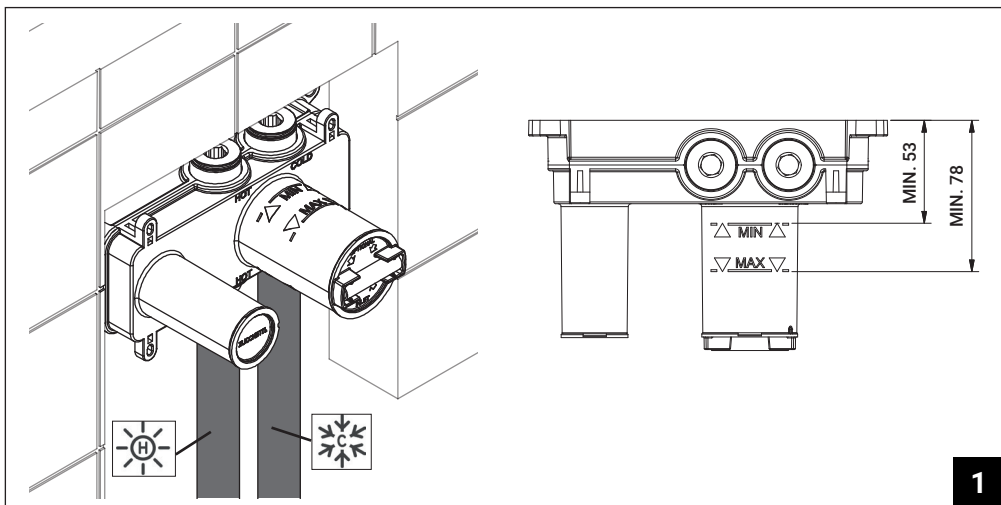
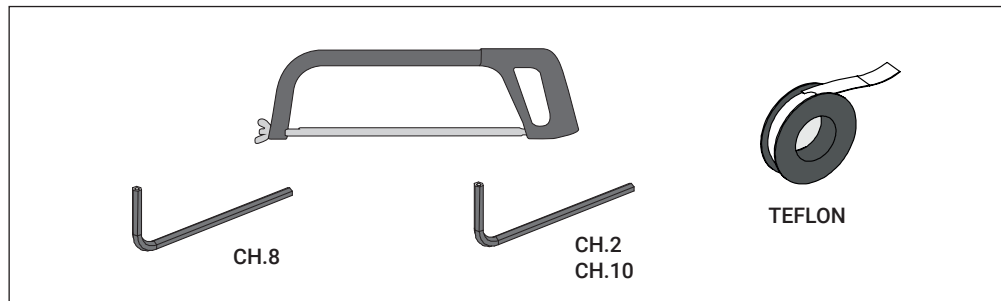

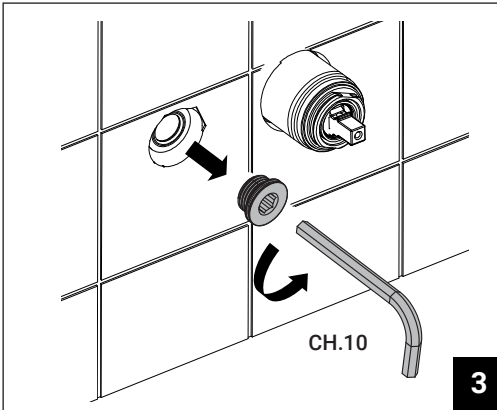

3

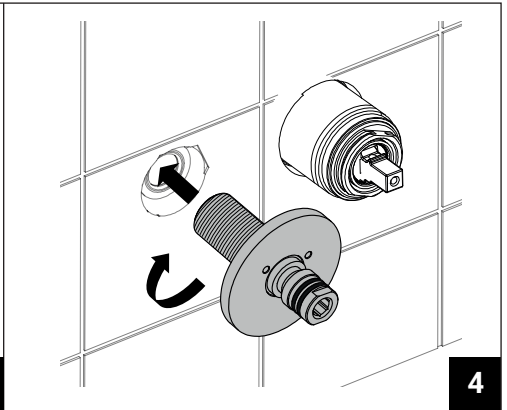

4

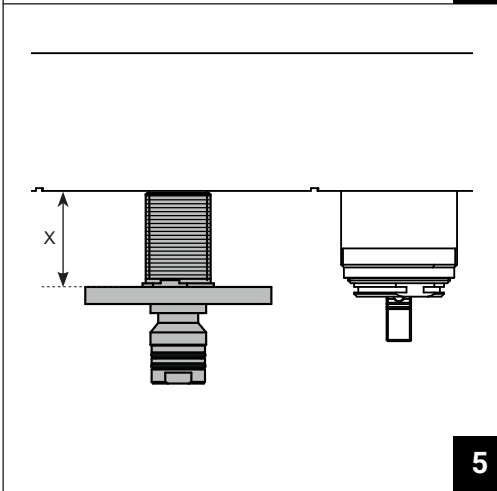

5

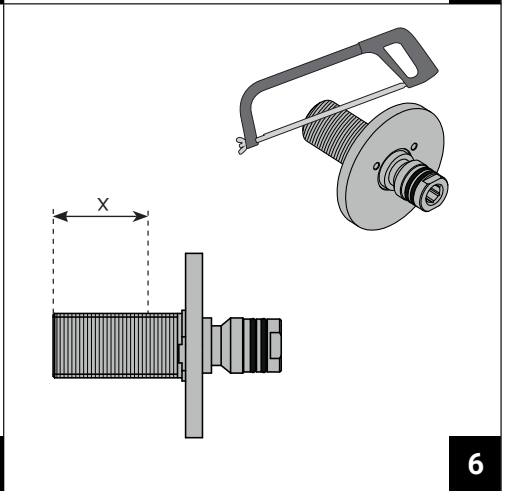

6

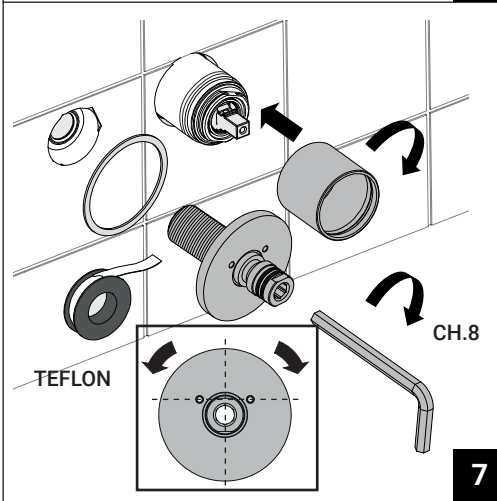

7

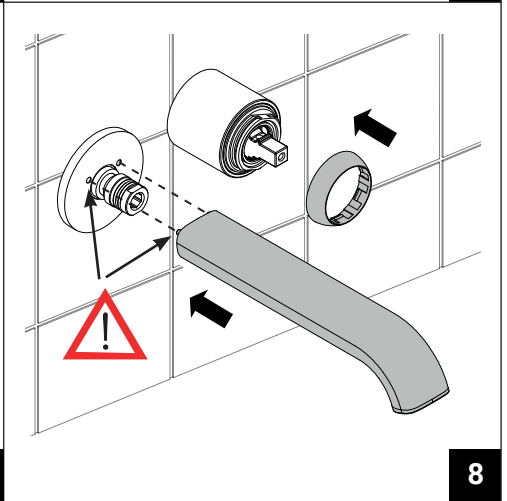

8

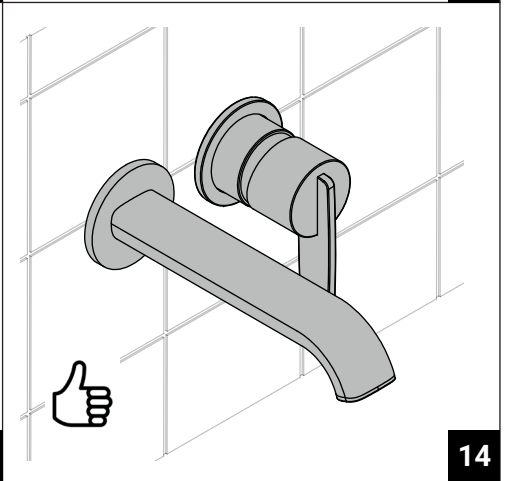
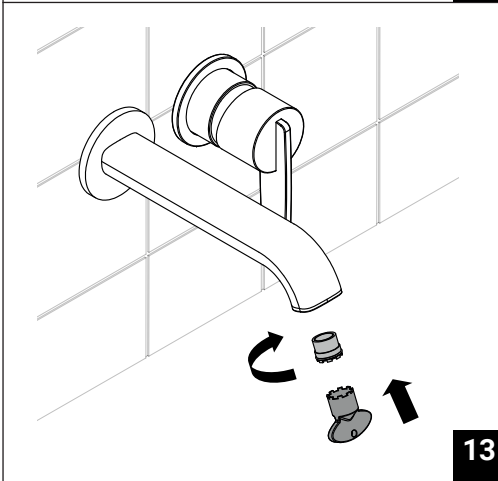
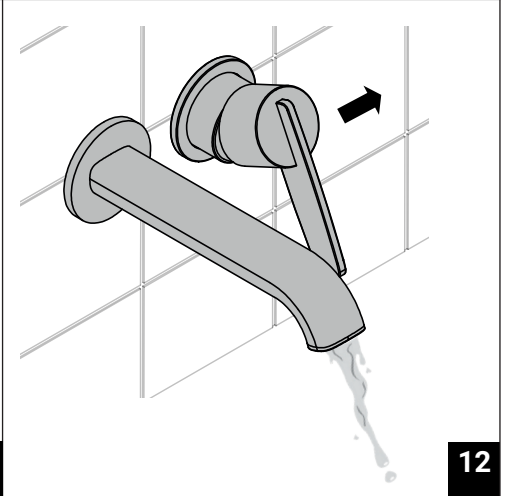
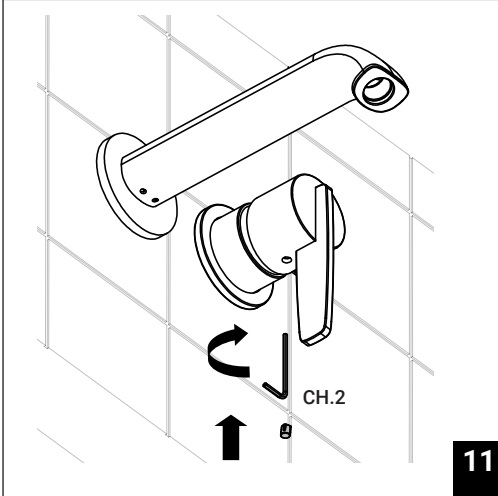
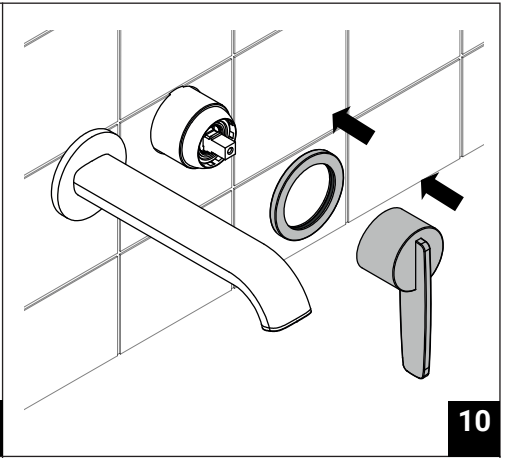
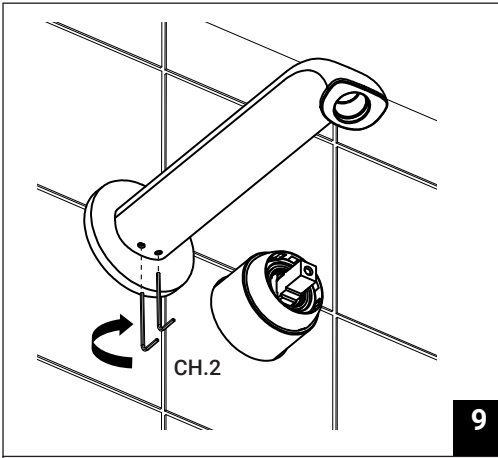

Installazione - Installation

ZVE775-ZVE776

Utensili necessari - Necessary tools



CH.17



CH. 2

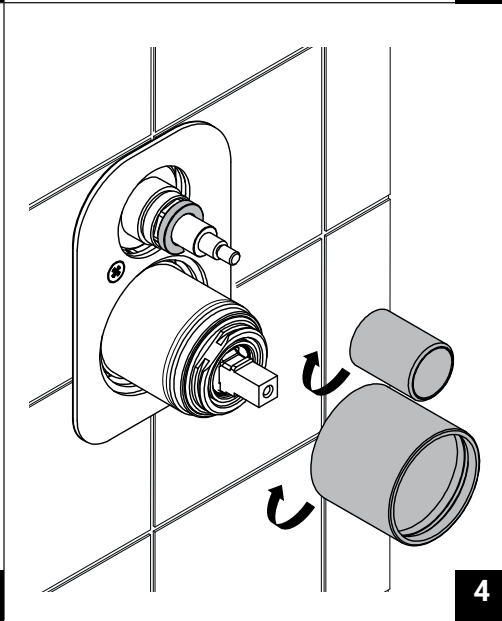
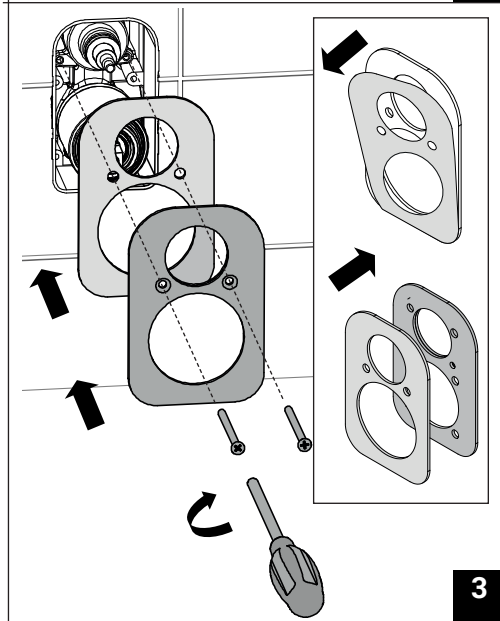
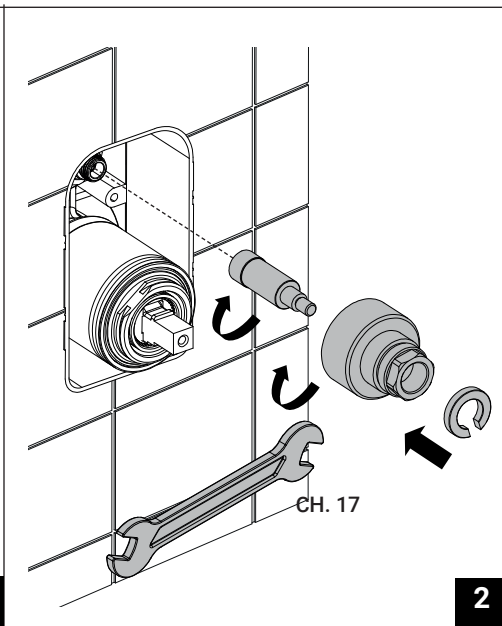
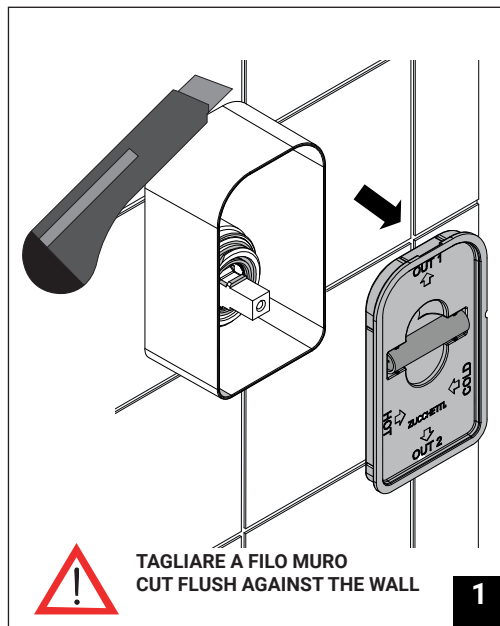

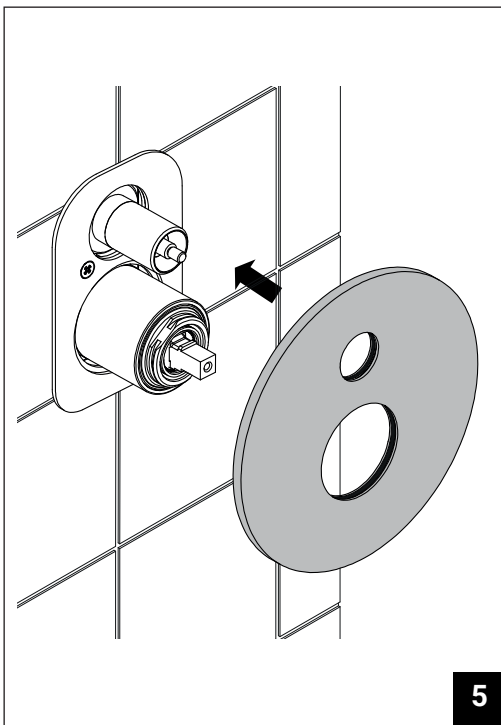

5

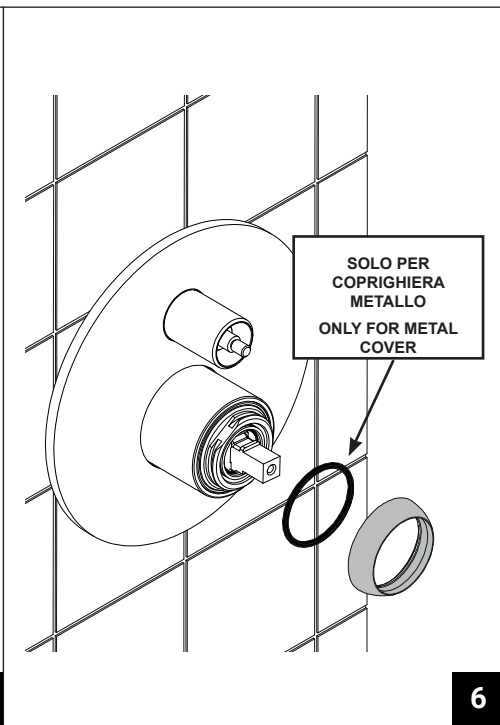

6

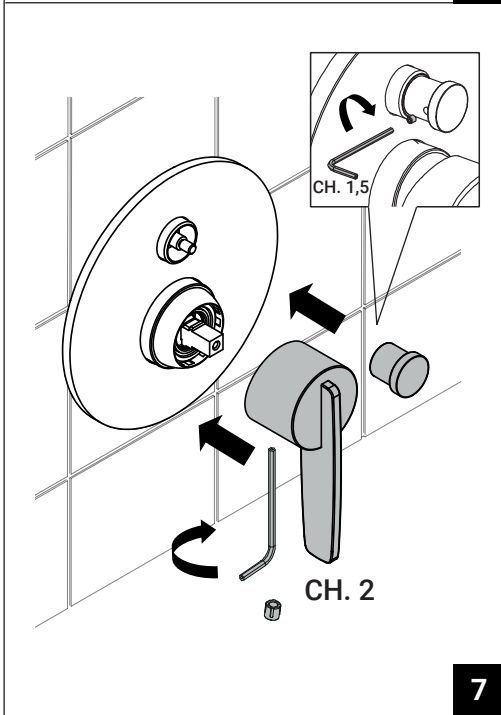

7

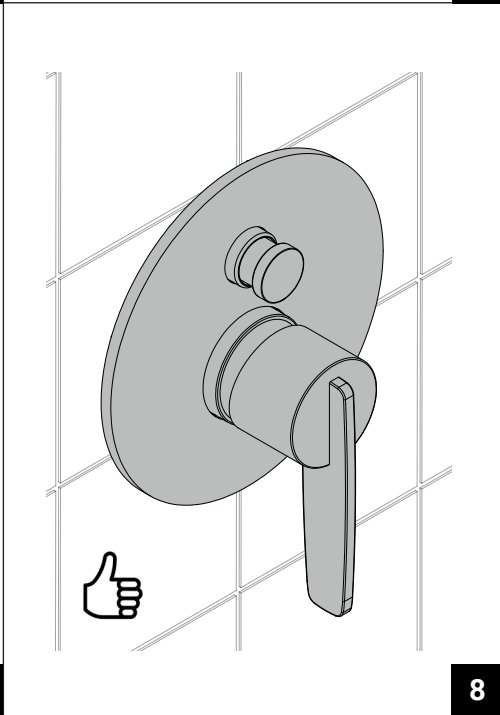

8

ZVE776

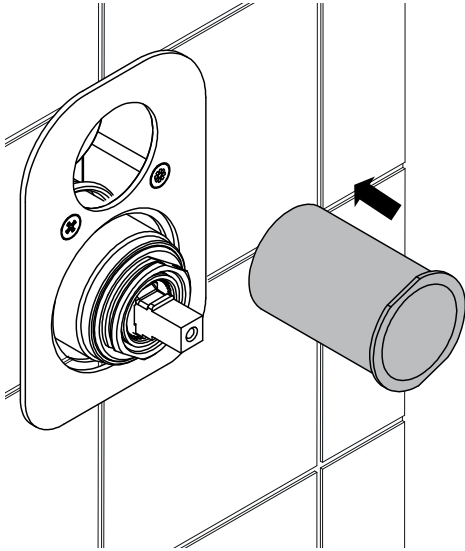

4

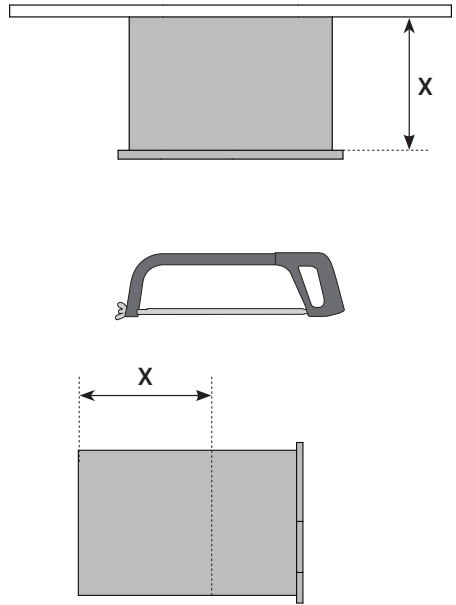

5

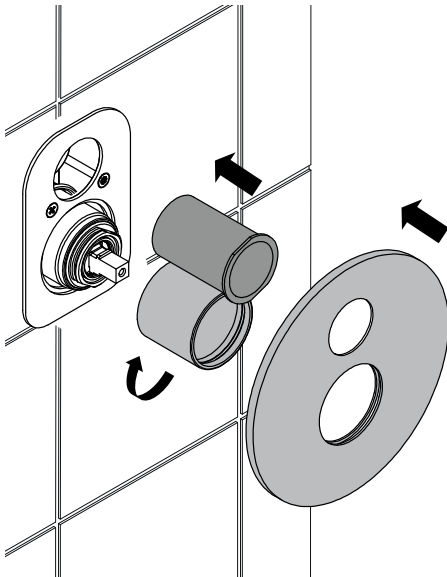

6

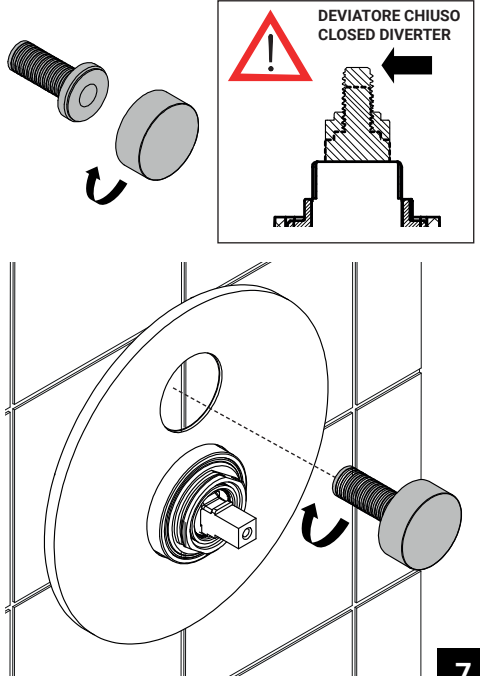

7

ZVE776

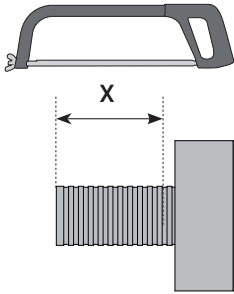
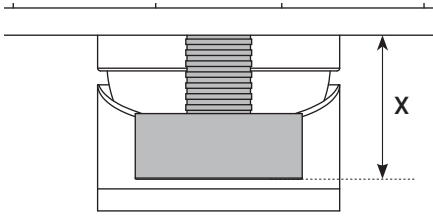

8

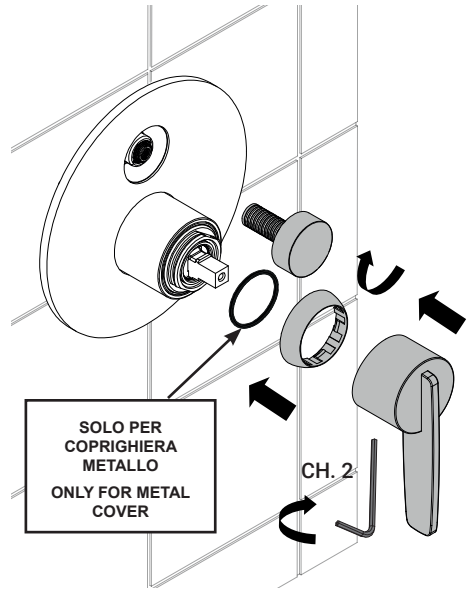

9

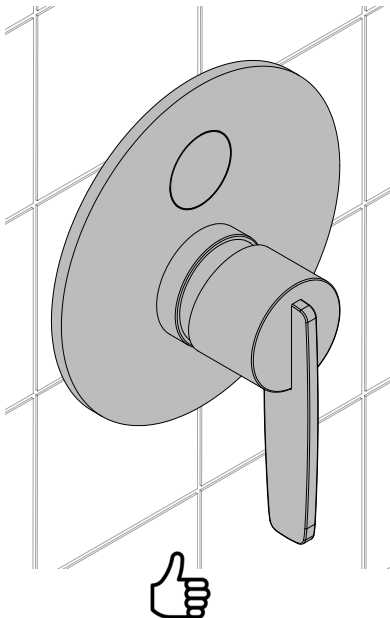

10

Installazione - Installation

ZVE778-ZVE780-Z94633

Utensili necessari - Necessary tools

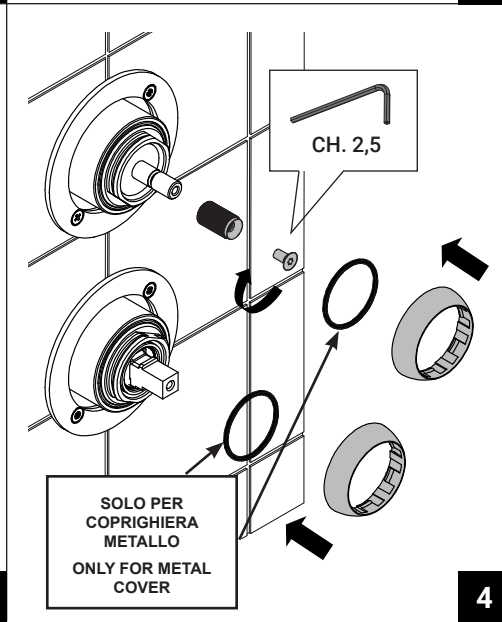
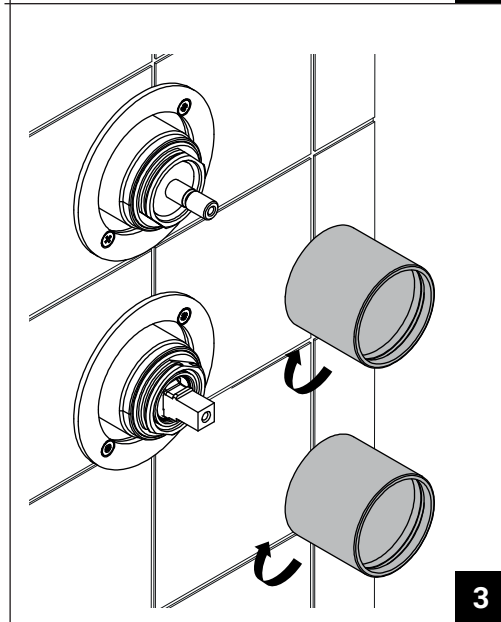
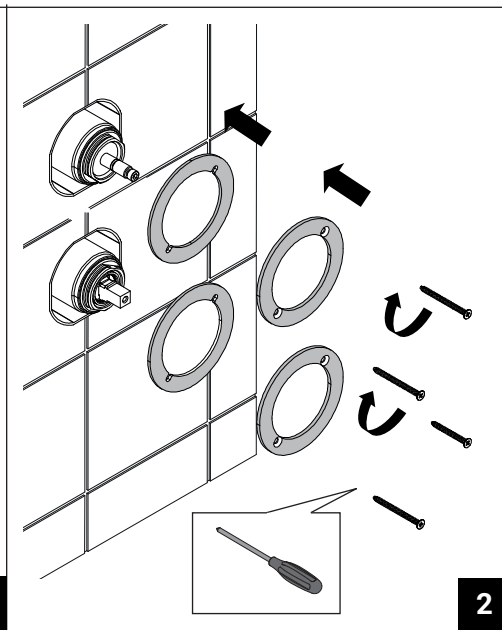
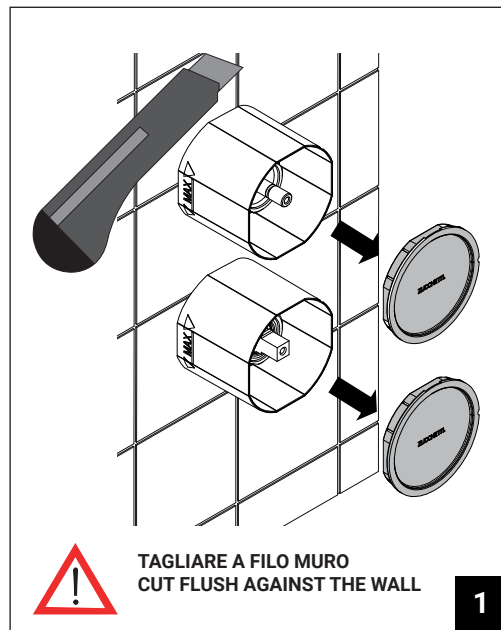
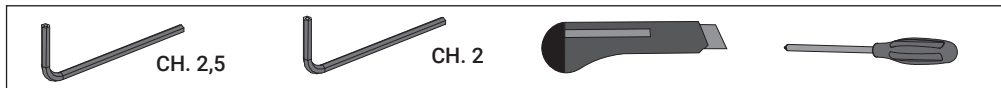

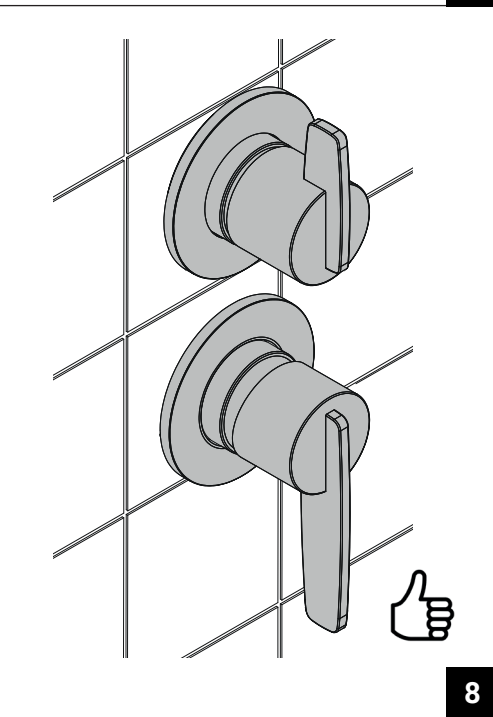
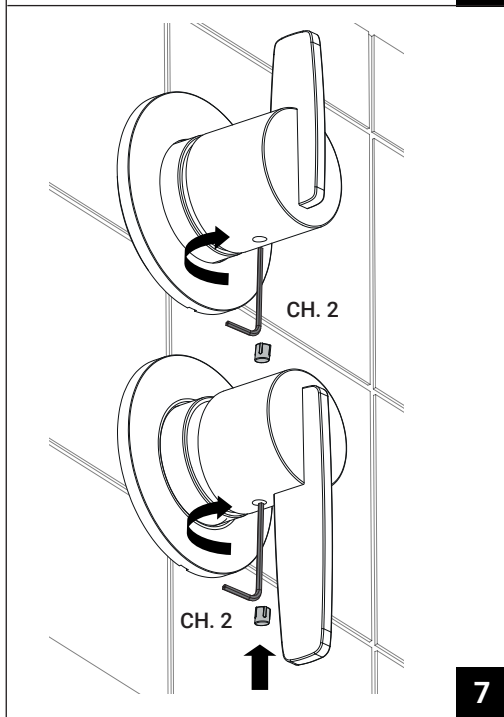
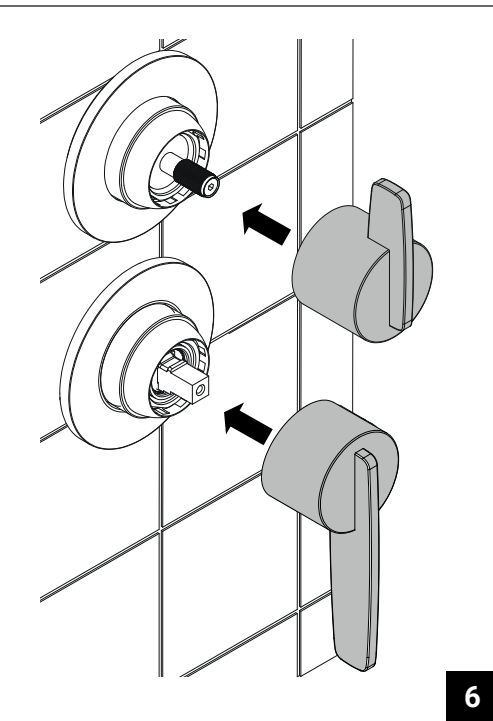
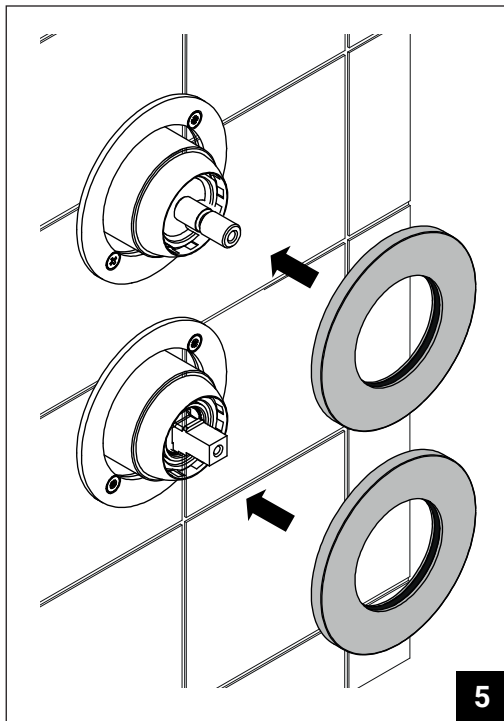

Installazione - Installation

ZVE417

Utensili necessari - Necessary tools

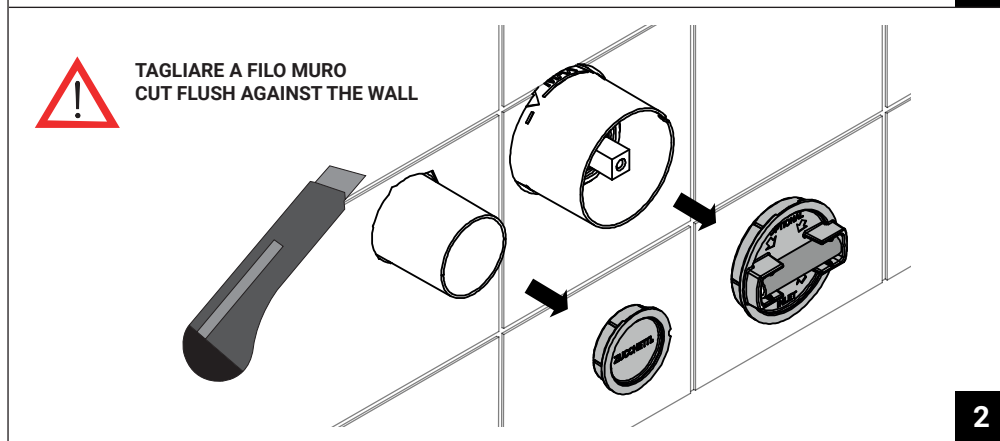
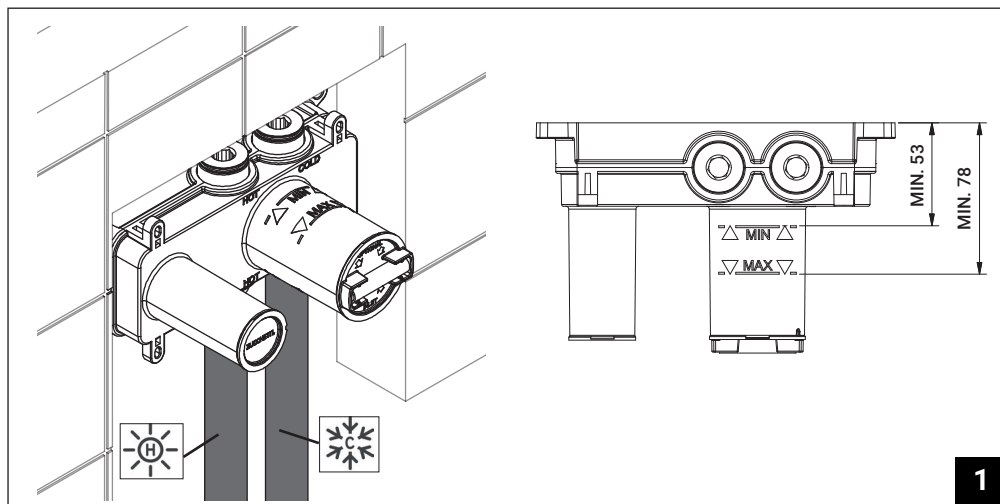
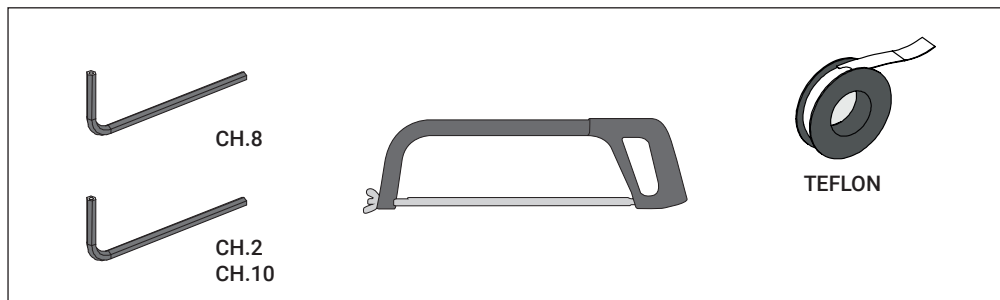

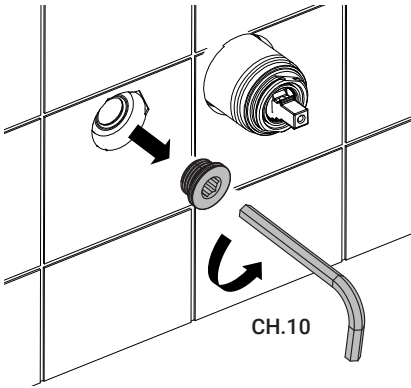

3

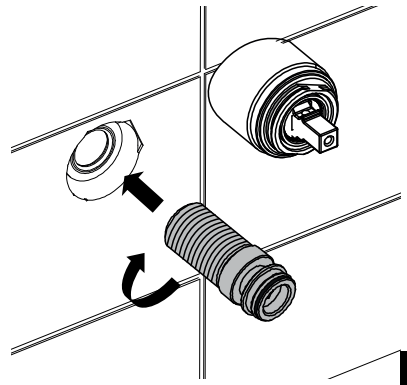

4

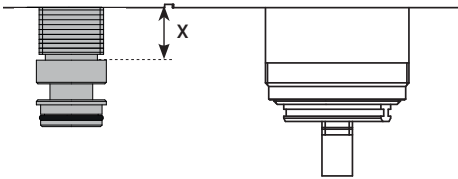

TAGLIARE A FILO MURO
CUT FLUSH AGAINST THE WALL

5

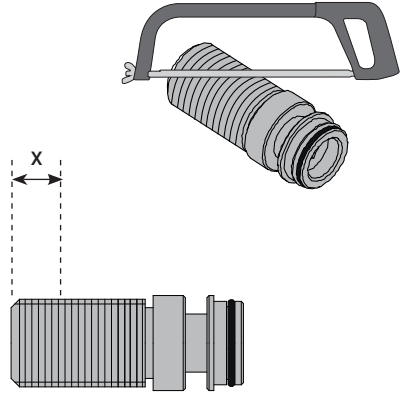

6

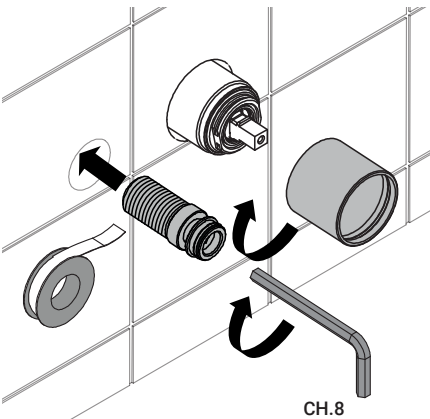

7

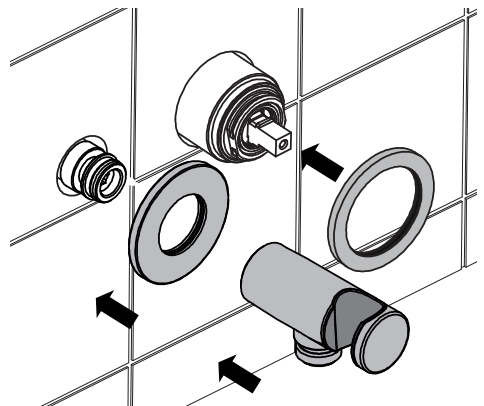

8

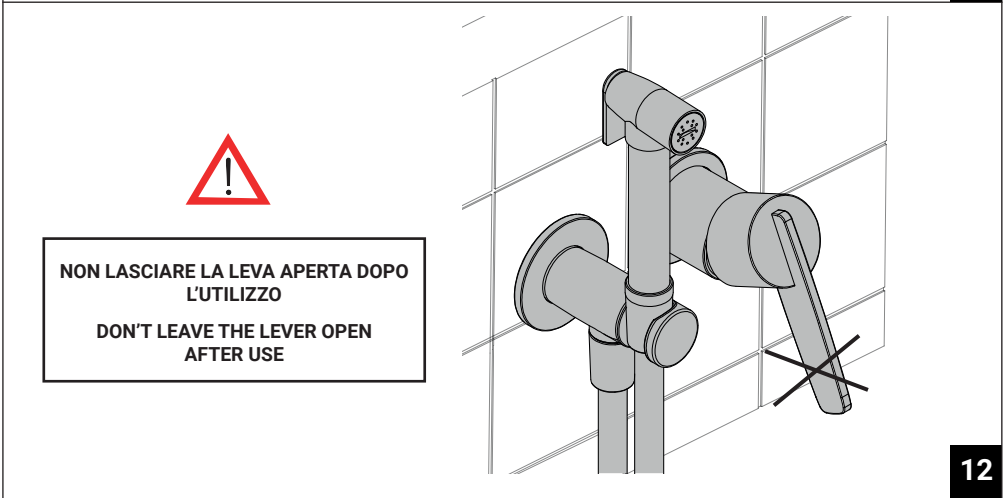
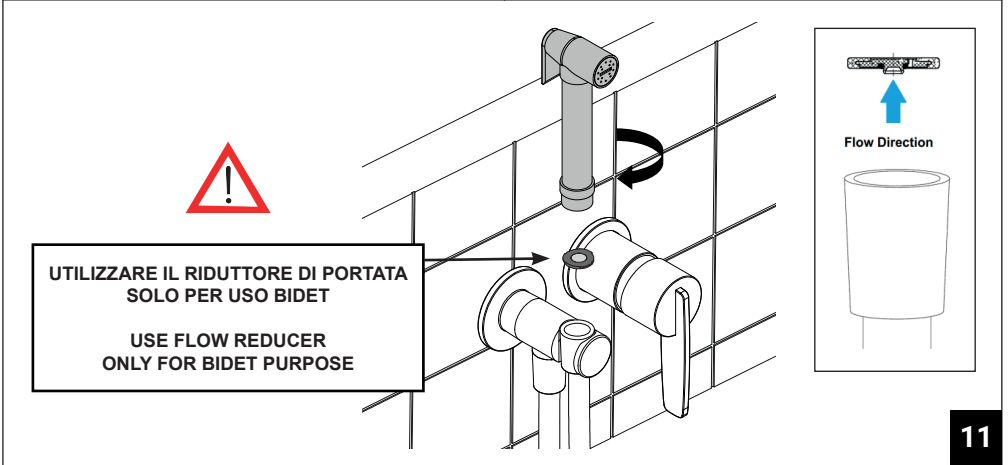
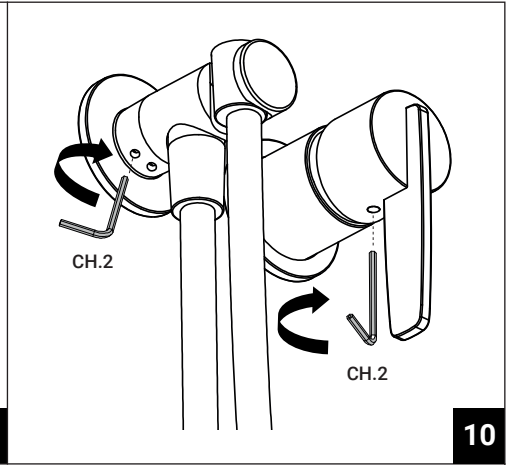

Sostituzione cartuccia - Cartridge replacement

ZVE546-ZVE547-ZVE548-ZVE549

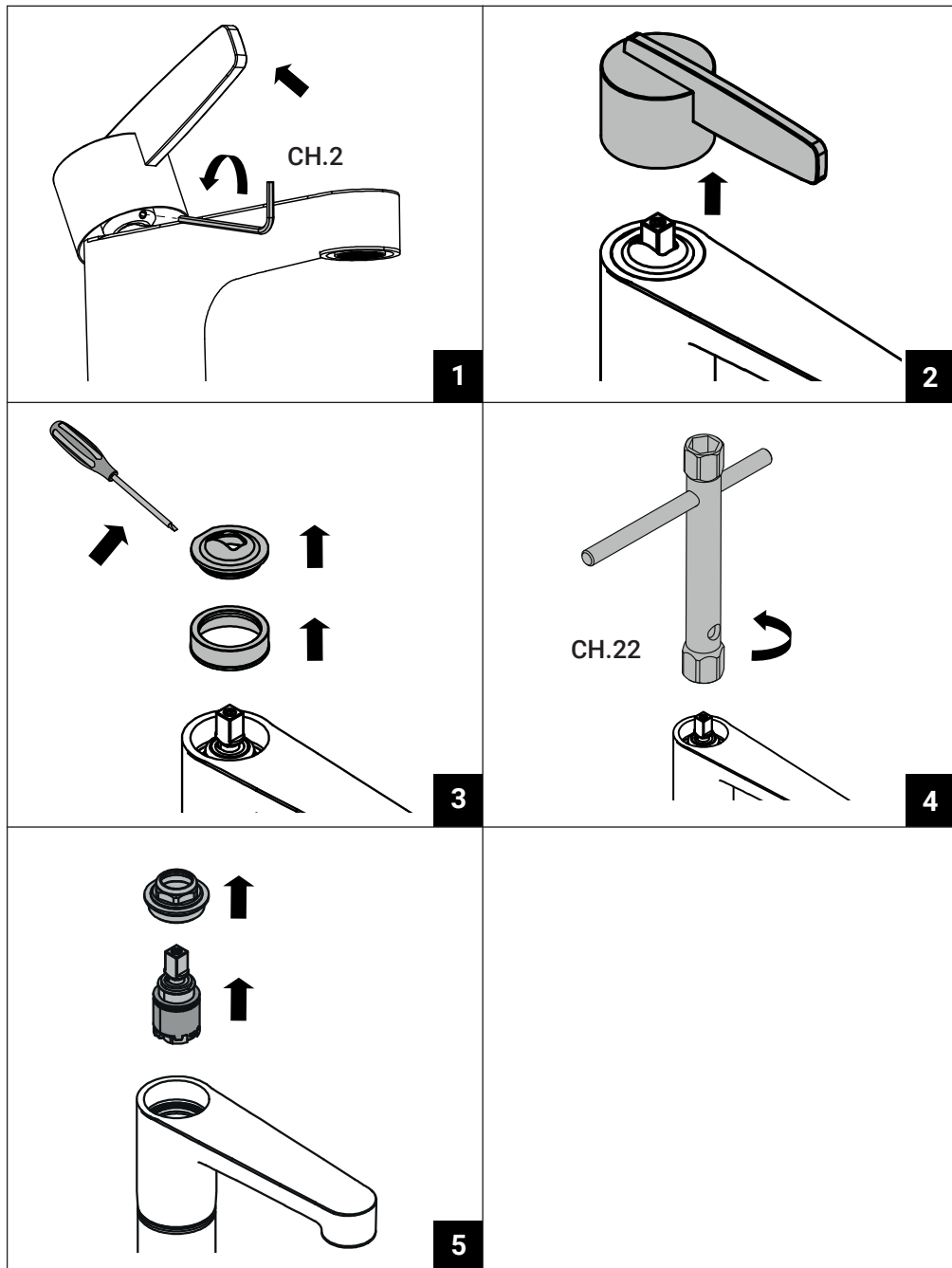

Sostituzione cartuccia - Cartridge replacement

ZVE435-ZVE436-ZVE437-ZVE775-ZVE776-ZVE778-ZVE780-ZVE417

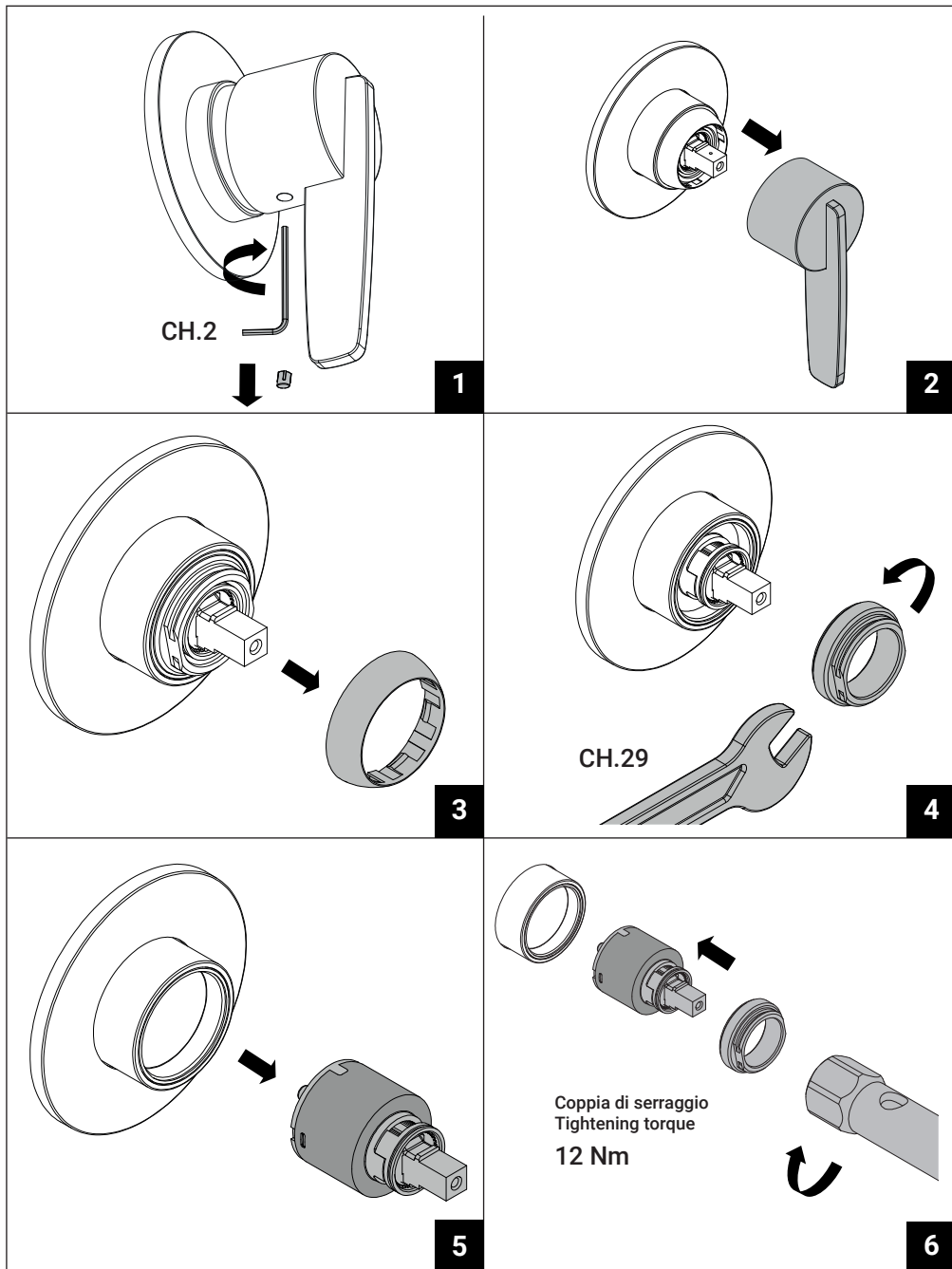

Pulizia e manutenzione / Cleaning and maintenance

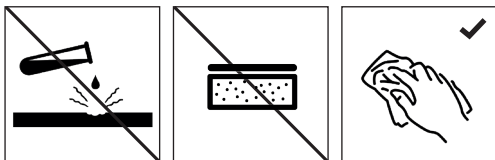

PULIZIA

Per la pulizia di tutta la nostra rubinetteria nelle versioni cromate, dorate, verniciate o finiture particolari, si raccomanda di evitare nel modo più assoluto l'uso di sostanze corrosive, abrasive, alcoliche, che possono danneggiare le superfici. Si consiglia di usare panni morbidi o spugne imbevute di acqua pulita. Nostro prodotto detergente ZETABRILL.

CLEANING

To clean all our taps in the chromed, gold plated or varnished versions or those with special finishes, we strongly advice against the use in all cases of corrosive and abrasive substances and those which contain alcohol, which may damage surfaces. We advice using soft cloths or sponges soaked in clean water. For best result use our detergent product ZETABRILL.

NETTOYAGE

Pour nettoyer toute notre robinetterie dans les versions chromées, dorées, colorées ou finitions particulières, il est recommandé d'éviter de la manière la plus absolu d'employer des substances corrosives, abrasives ou alcooliques, risquant d'endommager les surfaces. Nous vous conseillons d'employer des chiffons doux ou des éponges imbibées d'eau propre. Notre produit détergent ZETABRILL.

REINIGUNG

Zur Reinigung all unserer Armaturen in sämtlichen verchromten, vergoldeten, lackierten Ausführungen oder Spezialoberflächenveredlungen dürfen auf keinen Fall korrodierende, scheuernde oder alkoholhaltige Mittel verwendet werden, die die Oberflächen beschädigen können. Es empfiehlt sich, weiche Lappen oder mit klarem Wasser getränkte Schwämme zu verwenden. Unser Reinigungsmittel ist ZETABRILL.

LIMPIEZA

Para la limpieza de toda nuestra grifería en las versiones cromadas, doradas, barnizadas o con acabados particulares, se recomienda evitar absolutamente el uso de substancias corrosivas, abrasivas, alcohólicas, que puedan dañar las superficies. Se aconseja usar paños suaves o esponjas embebidas en agua limpia. Nuestro producto detergente ZETABRILL.

ЧИСТКА

Для ухода за смесителями с отделкой хром, золото, цветной или специальной абсолютно запрещается использовать коррозионные, абразивные вещества и алкоголь - это может привести к повреждению поверхности смесителя. Рекомендуется пользоваться мягкой тканью или губкой, смоченной водой. Вы можете воспользоваться чистящим средством ZETABRILL.

CZYSZCZENIE

Do czyszczenia wszystkich produktów Zucchetti, zarówno chromowanych, złoczonych, malowanych, jak i w innych, specjalnych wykończeniach, absolutnie nie wolno stosować substancji korodujących, ściernych czy zawierających alkohol, które mogłyby uszkodzić powłokę baterii. Armaturę czyścić miękką szmatką lub gąbką namoczoną w czystej wodzie. Polecamy również firmowy środek czyszczący ZETABRILL.

Pulizia dell'aeratore / Aerator cleaning

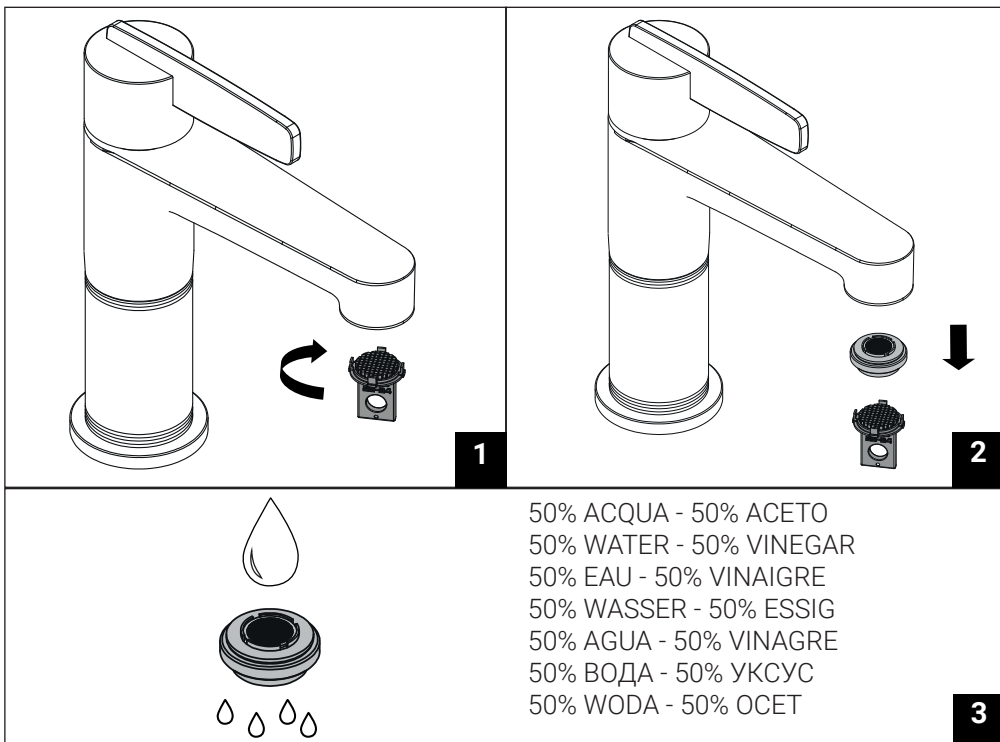

Condizioni di utilizzo / Conditions of use

CONDIZIONI DI UTILIZZO

Pressione minima: 1 bar **Pressione massima:** 5 bar **Pressione consigliata:** 2-3 bar

Differenza di pressione acqua calda/fredda: 1 bar max. **Temperatura massima:** 80°C **Temperatura consigliata:** 60-65°C

La rubinetteria Zucchetti può essere impiegata con scaldabagni elettrici ad accumulazione, a gas istantanei, impianti centralizzati, caldaie murali a gas miste e telericaldamento. Prima di collegare la rubinetteria si raccomanda di spurgare l'impianto. Nel caso di pressione dell'acqua superiore a 5 bar, è bene installare a monte della tubatura di alimentazione un riduttore di pressione; valori troppo elevati di pressione possono generare vibrazioni acustiche e fischi, inoltre irregolare regolazione della temperatura.

CONDITIONS OF USE

Minimum pressure: 1 bar **Maximum pressure:** 5 bar **Recommended pressure:** 2-3 bar

Pressure difference between hot /cold water: 1 bar max. **Maximum temperature:** 80°C **Recommended temperat.:** 60-65°C

Zucchetti taps can be used with electric storage water heaters and instant gas types, centralised system, combi wall-mounted gas boilers and district heating systems. Before connecting the taps we recommend draining the system thoroughly. Should the water pressure be higher than 5 bar, a pressure reducer should be fitted upstream of the supply pipes. Excessively high pressure values can cause acoustic vibrations and whistling in the taps and irregular and uneven temperature regulation.

CONDITIONS D'UTILISATION

Pression minimum: 1 bar **Pression maximum:** 5 bar **Pression conseillée:** 2-3 bar

Différence de pression entre eau chaude/froide: 1 bar max. **Température maximum:** 80° C **Température conseillé:** 60-65° C

La robinetterie Zucchetti peuvent être employés avec des chauffe-eau électriques à accumulation et à gaz instantanés, des installations centralisées, des chaudières murales à gaz mixtes et le téléchauffage. Avant de monter la robinetterie, n'oubliez pas de purger soigneusement l'installation. Si la pression de l'eau est supérieure à 5 bar, il est conseillé d'installer un réducteur de pression en haut du tuyau d'alimentation car des valeurs de pression trop élevées risquent de générer des vibrations sonores et des sifflements dans la robinetterie, ainsi qu'un réglage irrégulier et non progressif de la température.

TECHNISCHE DATEN

Mindestdruck: 1 Bar **Hochsterdruck:** 5 Bar **Empfohlener Betriebsdruck:** 2-3 Bar

Druckunterschied zwischen Warm- und Kaltwasser: 1 Bar max. **Heisswassertemperatur:** 80° C **Empfohlene Heisswassertemperatur:** 60-65° C

Die Armaturen von Zucchetti können in Verbindung mit elektrischen Heisswasserbereitern, Gas-Durchlauferhitzern, zentralisierten Heizanlagen, Gas-Wandboilern und Fernheizanlagen verwendet werden. Vor dem Anschluss der Armaturen an die Anlage muß diese gründlich gereinigt und entleert werden. Beträgt der Wasserdruck über 5 Bar, sollte in der Zulaufleitung ein Druckminderer montiert werden; überhöhte Druckwerte können akustische Schwingungen und Pfeiftöne in der Armatur erzeugen und eine ungleichmäßige und nicht progressive Temperaturregelung zur Folge haben.

CONDICIONES DE UTILIZACIÓN

Presión mínima: 1 bar **Presión máxima:** 5 bar **Presión aconsejada:** 2-3 bar

Diferencia de presión agua caliente/fría: 1 bar max. **Temperatura máxima:** 80°C **Temperatura aconsejada:** 60-65°C

La grifería Zucchetti puede ser empleada con calentadores de agua eléctricos de acumulación, de gas instantáneos, instalaciones centralizadas, caldares murales de gas mixtas y tele-calentamiento. Antes de conectar la grifería se recomienda purgar cuidadosamente la instalación. En caso de presión del agua superior a 5 bar, es conveniente instalar arriba de la tubería de alimentación un reductor de presión; valores demasiado elevados de presión pueden generar vibraciones acústicas y sibidos en la grifería y una regulación de la temperatura irregular.

УСЛОВИЯ ЭКСПЛУАТАЦИИ

Минимальное давление: 1 бар. **Максимальное давление:** 5 бар. **Рекомендуемое давление:** 2-3 бар.

Разница давления горячей/холодной воды: 1 бар макс. **Максимальная температура:** 80°C. **Рекомендуемая температура:** 60-65°C.

Смесительная арматура Zucchetti может использоваться с электрическими накопительными нагревателями, проточными газовыми нагревателями, централизованным оборудованием, настенными газовыми нагревателями смешанного типа и нагревателями с электронным управлением. Перед подключением смесителя рекомендуется промыть систему. Кроме того. Если давление в системе выше 5 бар, на входе необходимо установить редуктор давления, слишком высокое давление создает звуковую и физическую вибрацию, кроме того возможна неточная регулировка температуры.

WARUNKI EKSPLOATACJI

Ciśnienie minimalne: 1bar **Ciśnienie maksymalne:** 5 bar **Ciśnienie zalecane:** 2-3 bar

Różnica ciśnień pomiędzy wodą ciepłą a zimną: 1 bar maks. **Temperatura maksymalna:** 80°C **Temperatura zalecana:** 60-65°C

Baterie firmy Zucchetti mogą być podłączone do instalacji wodnych współpracujących z boilerami elektrycznymi lub gazowymi przepływowymi podgrzewaczami wody, do instalacji centralnego ogrzewania oraz do instalacji z gazowymi kotłami wiszącymi. Przed podłączeniem baterii należy dokładnie przepłukać instalację. W przypadku, gdy ciśnienie wody w instalacji przekracza 5 bar wskazane jest zamontować przed doprowadzeniem wody do baterii reduktor ciśnienia. Zbyt wysokie ciśnienie wody powodować może wibracje akustyczne oraz świsty, jak i uniemożliwić prawidłową regulację temperatury.

ZUCCHETTI.

Zucchetti Rubinetteria S.p.A.

Via Molini di Resiga, 29 - 28024 Gozzano (No) - Italy - Tel. +39 0322 954700 - Fax +39 0322 954823
- www.zucchettidesign.it

