

# Zetasystem

I

ISTRUZIONI PER L'INSTALLAZIONE DELLA RUBINETTERIA

GB

INSTRUCTIONS FOR THE INSTALLATION OF THE FAUCETS

D

MONTAGEANLEITUNGEN ZUR INSTALLATION DER ARMATUREN

F

INSTRUCTIONS POUR L'INSTALLATION DE LA ROBINETTERIE

R97800

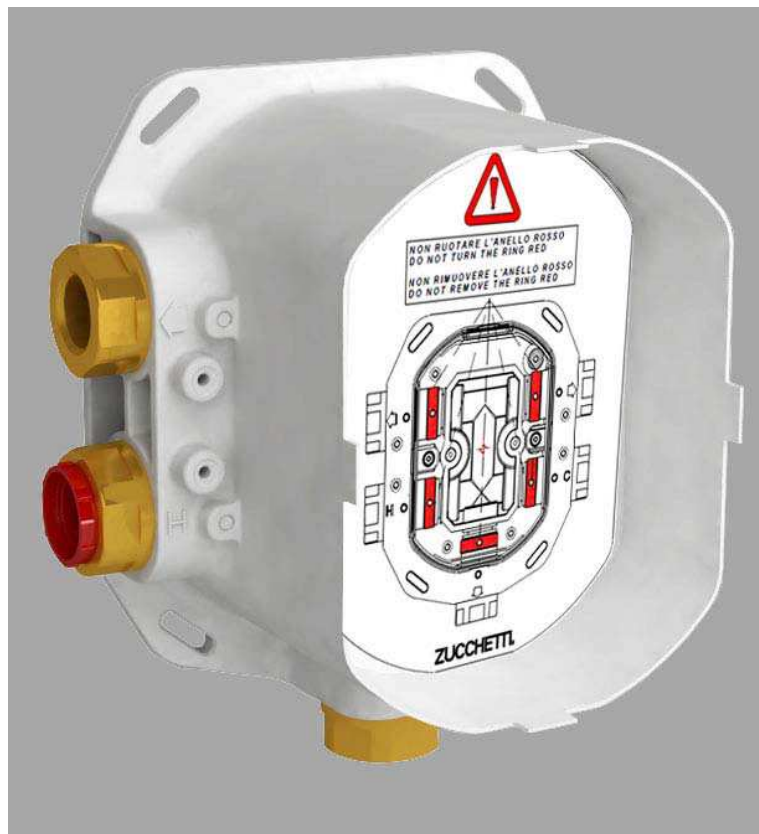

## ZUCCHETTI.

Zucchetti Rubinetteria S.p.A.

Via Molini di Resiga, 29 - 28024 Gozzano (No) - Italy - Tel. +39 0322 954700 - Fax +39 0322 954823 - zucchettdesign.it

IT

**DATI TECNICI**

**Pressione minima** : 1 bar  
**Pressione d'uso consigliata** : 2 - 3 bar  
**Pressione massima** : 5 bar max  
**Pressione di prova impianto** : 10 bar max  
**Temperatura acqua calda** : max 80°  
**Temperatura acqua calda consigliata** : 60°- 65°  
**Differenza di pressione acqua calda/fredda**: 1 bar max.

La rubinetteria Zucchetti può essere impiegata con scaldabagni elettrici ad accumulo, a gas istantanei, impianti centralizzati, caldaie murali a gas miste e teleriscaldamento. Prima di collegare la rubinetteria si raccomanda di spurgare l'impianto.

Nel caso di pressione dell'acqua superiore a 5 bar, è bene installare a monte della tubatura di alimentazione un riduttore di pressione; valori troppo elevati di pressione possono generare vibrazioni acustiche e fischi, inoltre irregolare regolazione della temperatura.

EN

**TECNICAL DATA**

**Minimum pressure** : 1 bar  
**Recommended** : 2 - 3 bar  
**Maximum pressure** : 5 bar max  
**Test pressure** : 10 bar max  
**Hot water temperature** : max 80°  
**Recommended hot water temp**: 60°- 65°  
**Pressure difference between hot / cold water** : 1 bar max.

Zucchetti taps can be used with electric storage water heaters and instant gas types, centralised system, combi wall-mounted gas boilers and district heating systems. Before connecting the taps we recommend draining the system thoroughly.

Should the water pressure be higher than 5 bar, a pressure reducer should be fitted upstream of the supply pipes. Excessively high pressure values can cause acoustic vibrations and whistling in the taps and irregular and uneven temperature regulation.

FR

**INFORMATIONS TECHNIQUES**

**Pression minimum**: 1 bar  
**Pression conseillée**: 2 - 3 bar  
**Pression maximum**: 5 bar max  
**Pression maximum de contrôle**: 10 bar max  
**Température maximum**: max 80°  
**Température conseillée**: 60°- 65°  
**Différence de pression entre eau chaude/froide**: 1 bar max.

La robinetterie Zucchetti peuvent être employés avec des chauffe-eau électriques à accumulation et à gaz instantanés, des installations centralisées, des chaudières murales à gaz mixtes et le téléchauffage. Avant de monter la robinetterie, n'oublier pas de purger soigneusement l'installation.

Si la pression de l'eau est supérieure à 5 bar, il est conseillé d'installer un réducteur de pression en haut du tuyau d'alimentation car des valeurs de pression trop élevées risquent de générer des vibrations sonores et des sifflements dans la robinetterie, ainsi qu'un réglage irrégulier et non progressif de la température.

DE

**TECHNISCHE DATEN**

**Mindestdruck**: 1 bar  
**Empfohlener Betriebsdruck**: 2 - 3 bar  
**Hochsterdruck**: 5 bar max  
**Früdruck**: 10 bar max  
**Heisswassertemperatur** : max 80°  
**Empfohlene Heisswassertemperatur** : 60°- 65°  
**Druckunterschied zwischen Warm- und Kaltwasser**: 1 bar max.

Die Armaturen von Zucchetti können in Verbindung mit elektrischen Heisswasserbereitern, Gas-Durchlauferhitzern, zentralisierten Heizanlagen, Gas-Wandboilern und Fernheizanlagen verwendet werden. Vor dem Anschluss der Armaturen an die Anlage muß diese gründlich gereinigt und entleert werden.

Beträgt der Wasserdruck über 5 Bar, sollte in der Zulaufleitung ein Druckminderer montiert werden; überhöhte Druckwerte können akustische Schwingungen und Pfeiftöne in der Armatur erzeugen und eine ungleichmäßige und nicht progressive Temperaturregelung zur Folge haben.



Miscelatore doccia  
Shower mixer  
Mitigeur douche  
Brousemischer



Termostatico con rubinetto  
di arresto  
Thermostatic mixer with  
shut off unit  
Mitigeur thermostatique  
avec robinet d'arrêt  
Thermostat mit absperventi



Miscelatore vasca / doccia  
Bath - shower mixer  
Mitigeur bains douches  
Wannenmischer

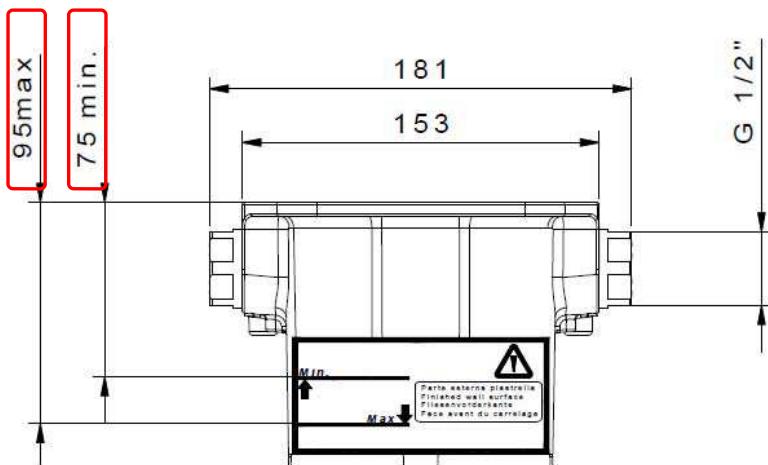
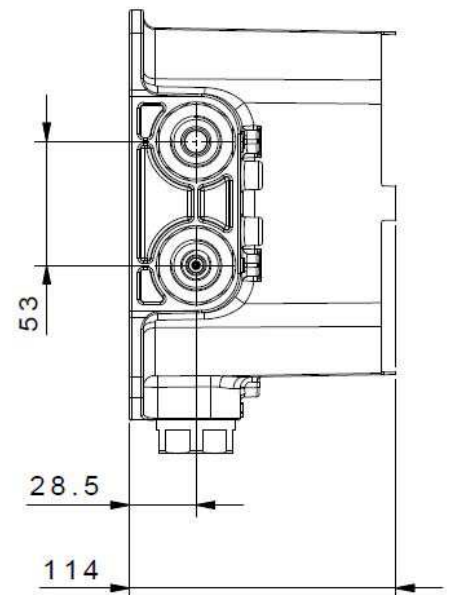
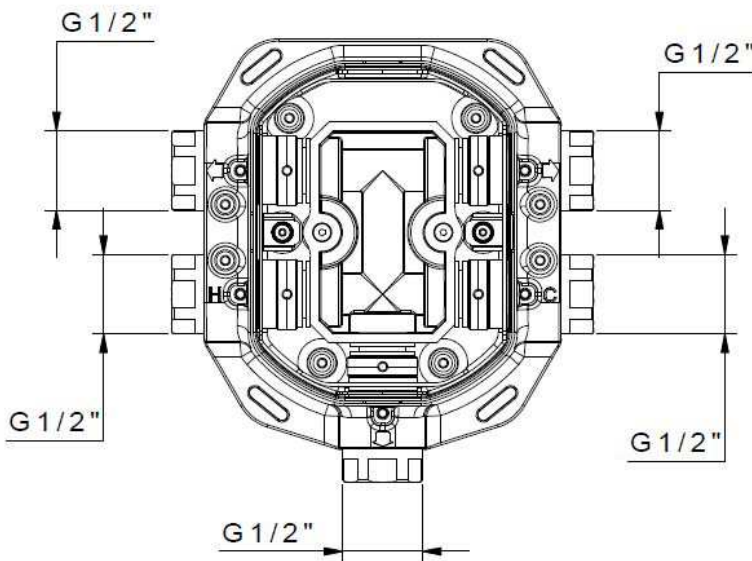

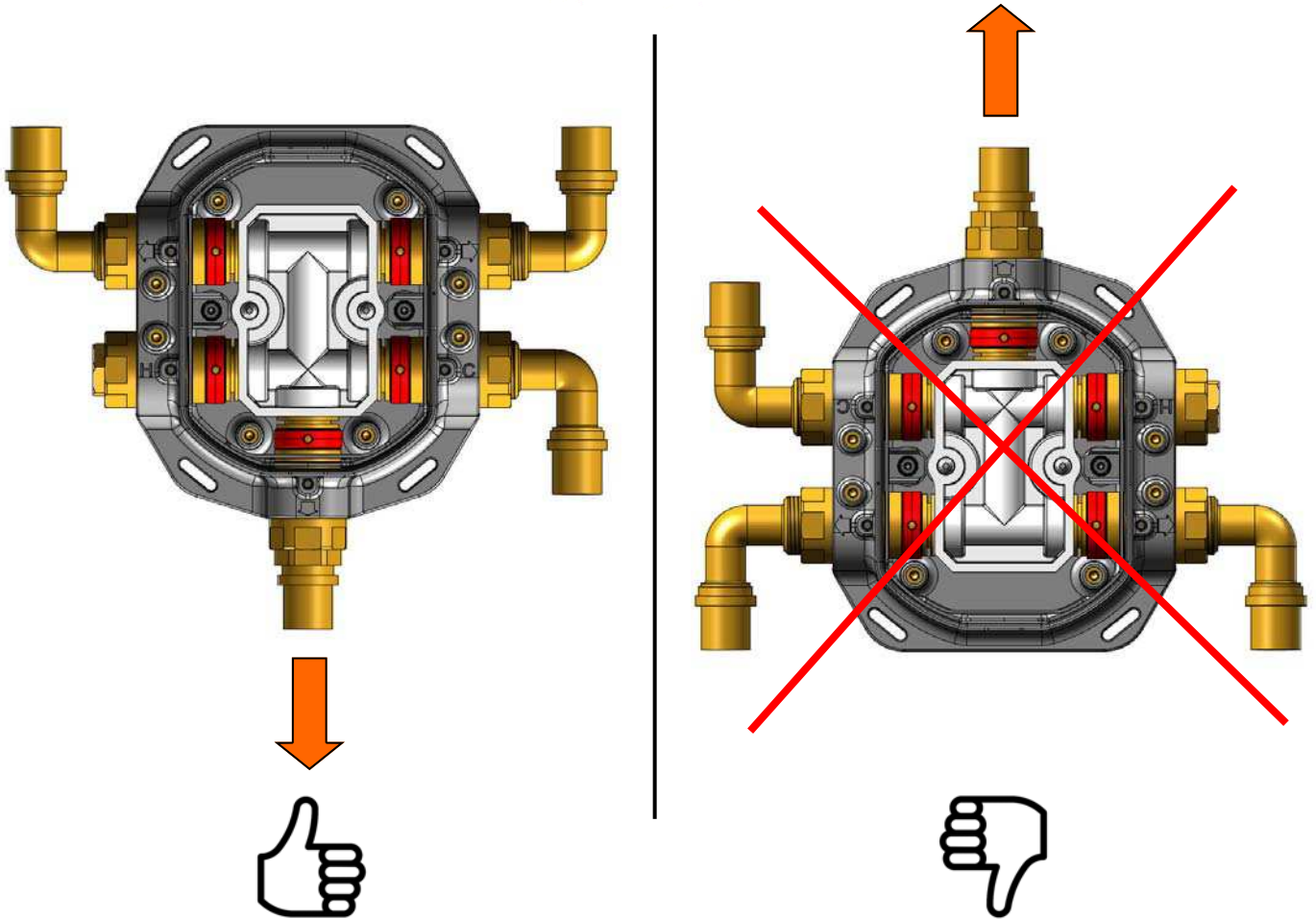
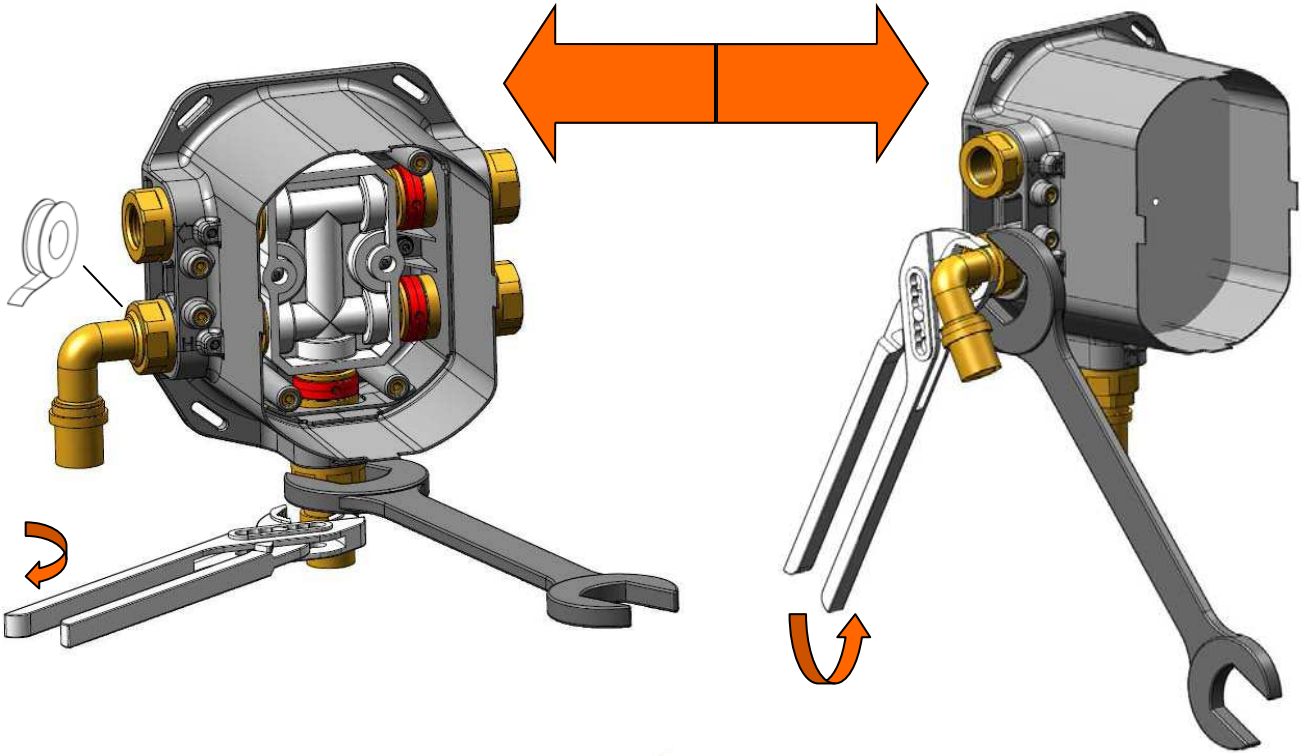

I

ESEMPI DI INSTALLAZIONE

GB

EXAMPLES OF INSTALLATION

D

EINBAUBEISPIELE

F

DES EXEMPLES DE L'INSTALLATION



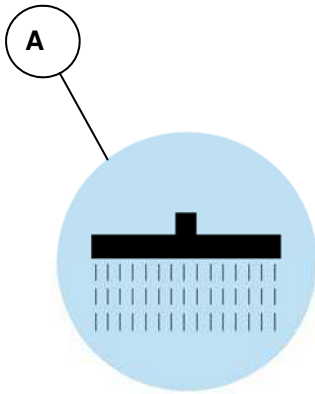

1° SOLUTION  
1° SOLUZIONE



  
NON RUOTARE L'ANELLO ROSSO  
DO NOT TURN THE RED RING  
NON RIMUOVERE L'ANELLO ROSSO  
DO NOT REMOVE THE RED RING



2° SOLUTION  
2° SOLUZIONE

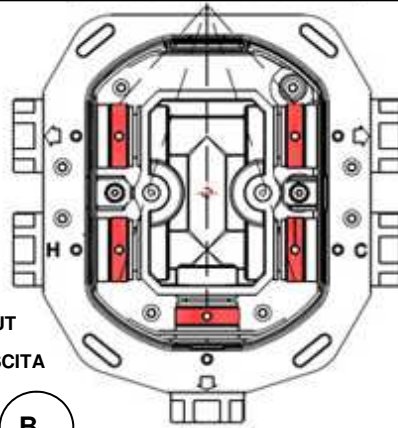

OUT  
USCITA



PLUG UNUSED OUTLET  
TAPPARE USCITA NON  
UTILIZZATA

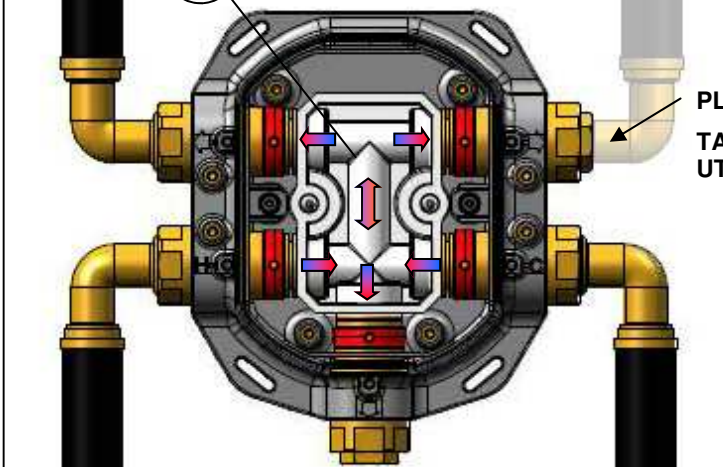

MAX 10 bar  
TESTING



HOT  
CALDA

COLD  
FREDDA



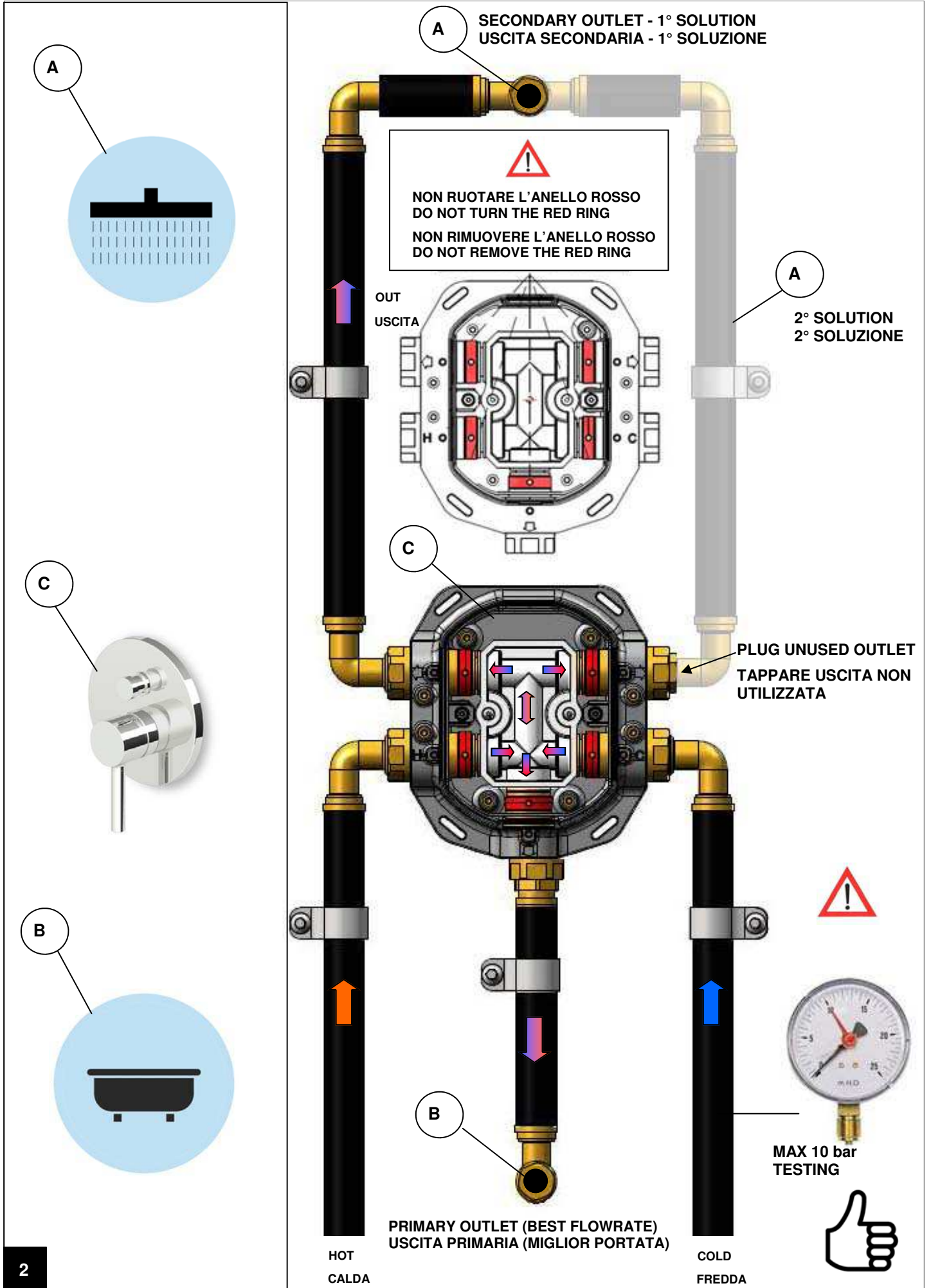



NON RUOTARE L'ANELLO ROSSO  
DO NOT TURN THE RED RING  
NON RIMUOVERE L'ANELLO ROSSO  
DO NOT REMOVE THE RED RING

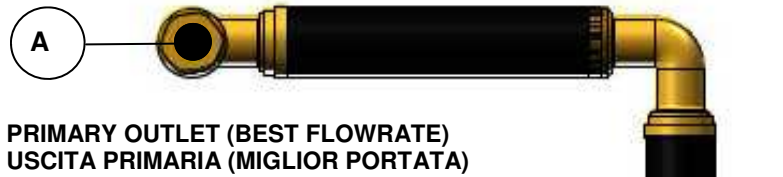
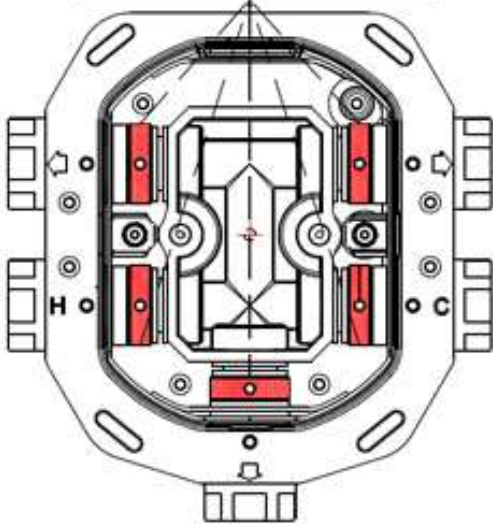

PRIMARY OUTLET (BEST FLOWRATE)  
USCITA PRIMARIA (MIGLIOR PORTATA)

PLUG UNUSED OUTLET  
TAPPARE USCITA NON  
UTILIZZATA



SECONDARY OUTLET - 1° SOLUTION  
USCITA SECONDARIA - 1° SOLUZIONE

OUT  
USCITA

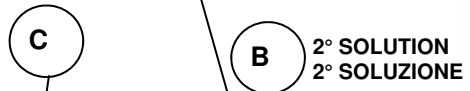

2° SOLUTION  
2° SOLUZIONE

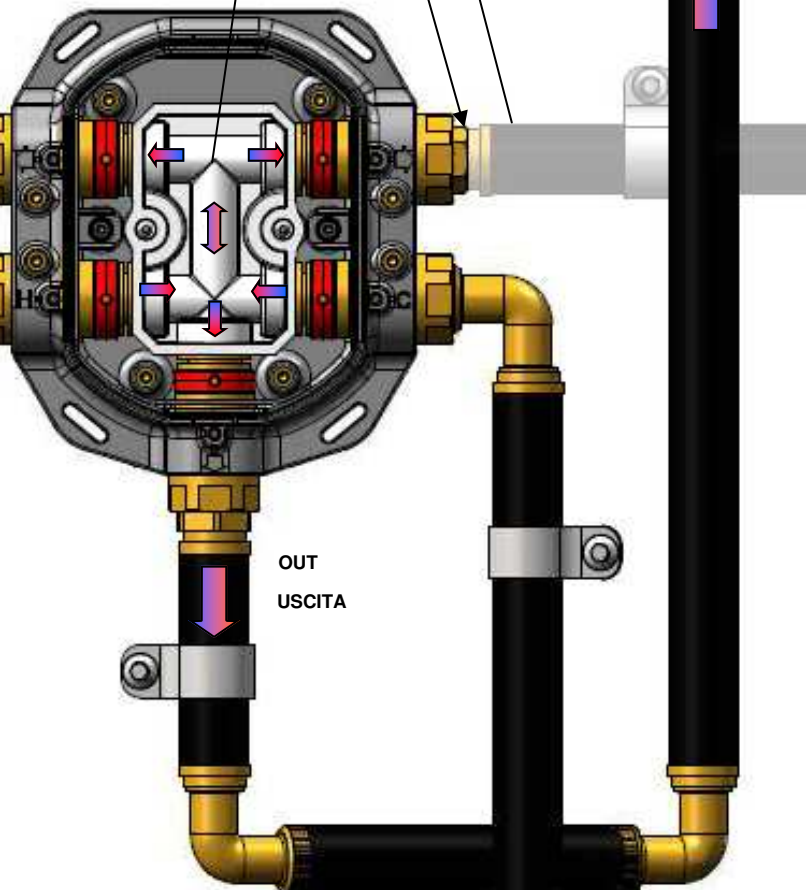

OUT  
USCITA

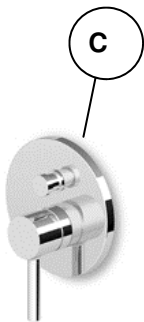
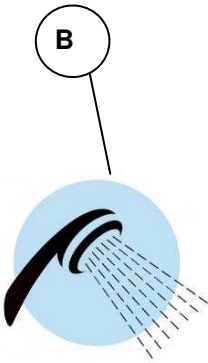
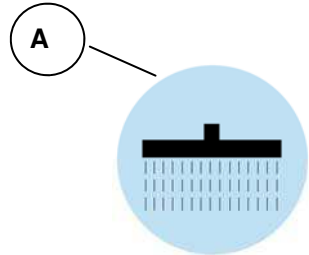

MAX 10 bar  
TESTING



HOT  
CALDA

COLD  
FREDDA



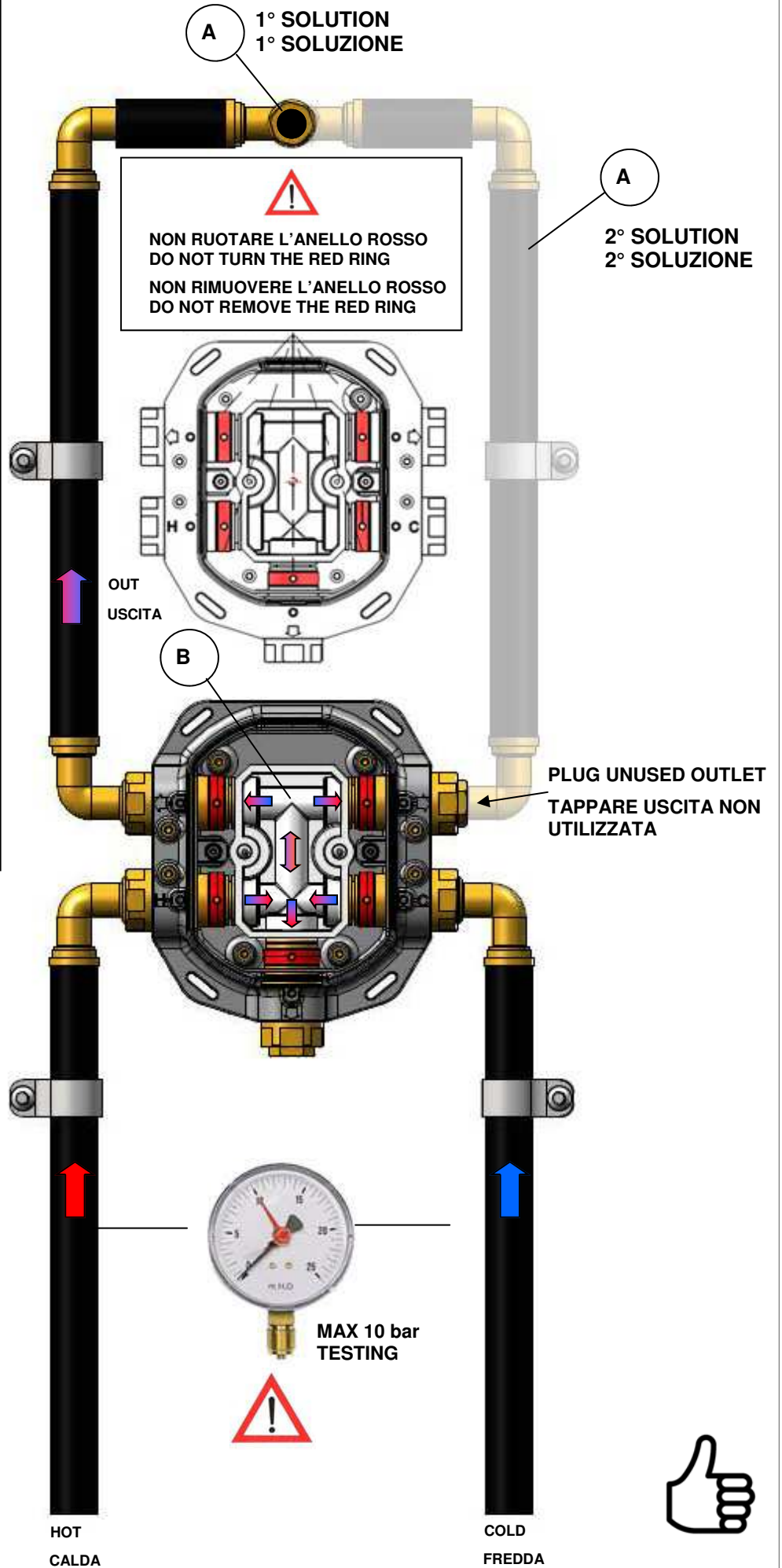
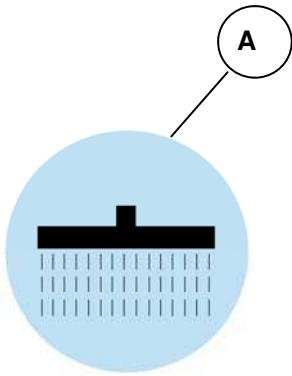

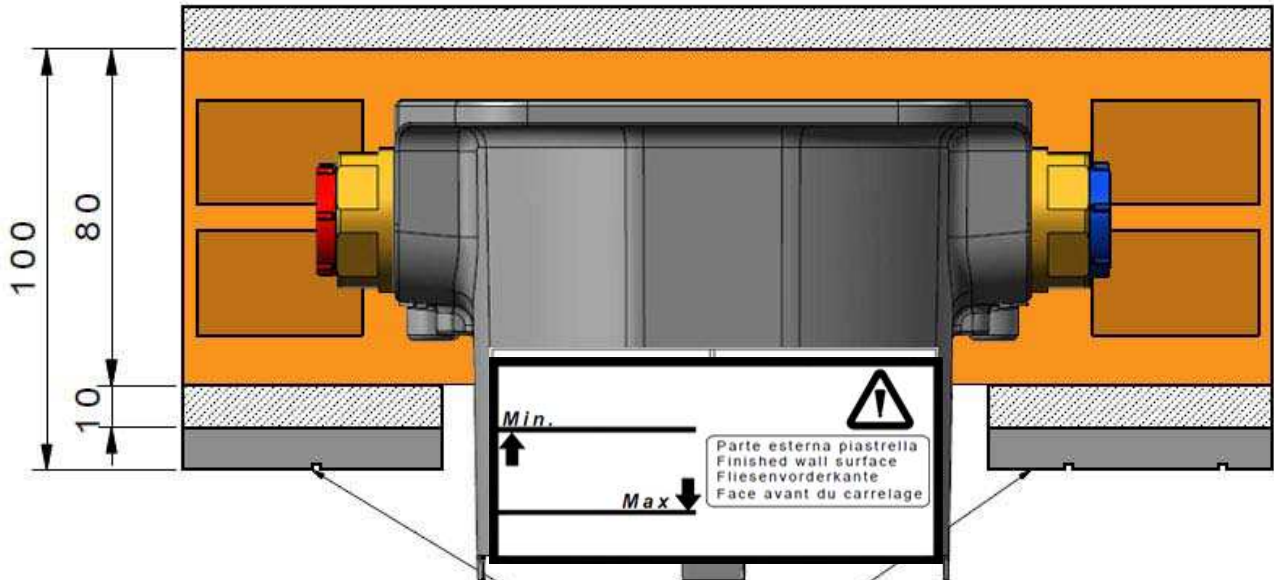

Parte esterna piastrella  
Finished wall surface  
Fliesenvorderkante  
Face avant du carrelage

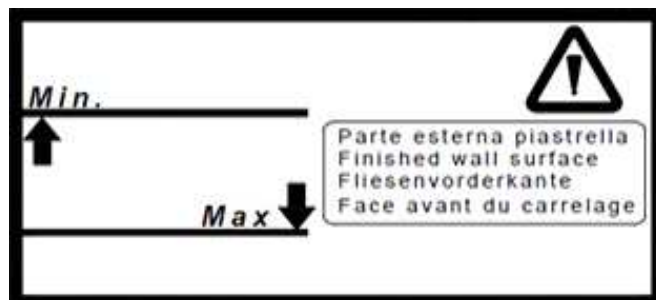
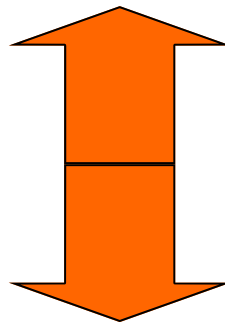

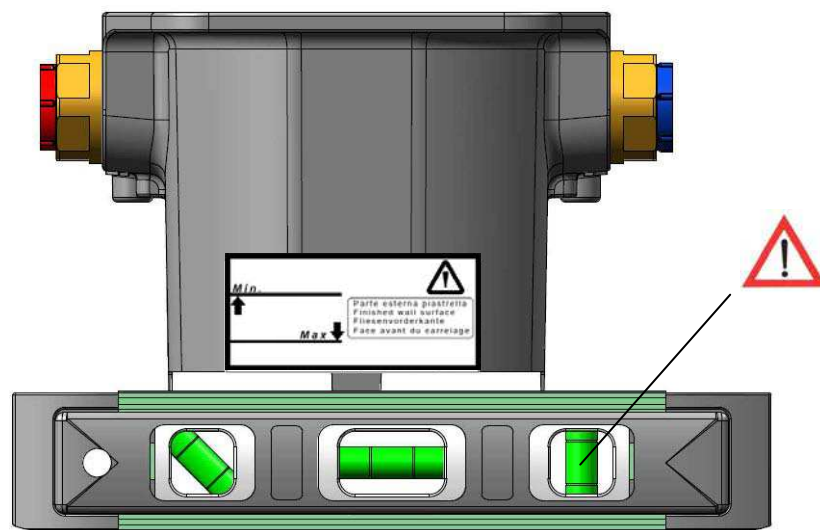
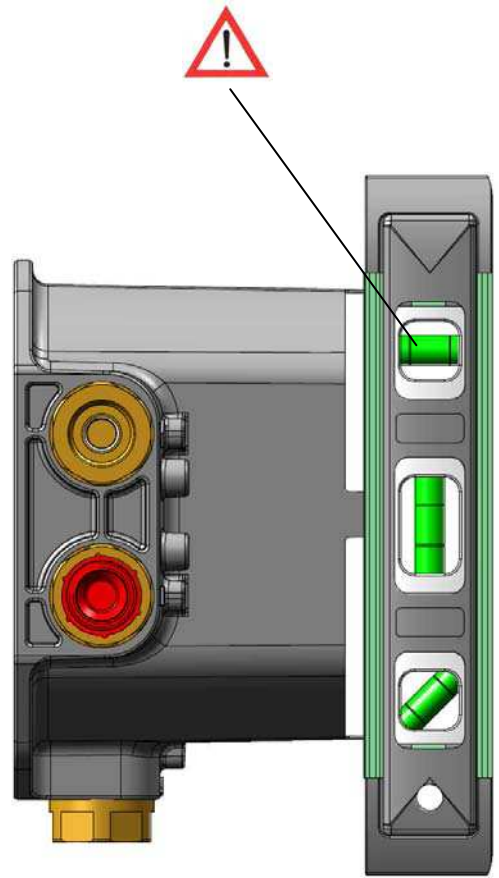
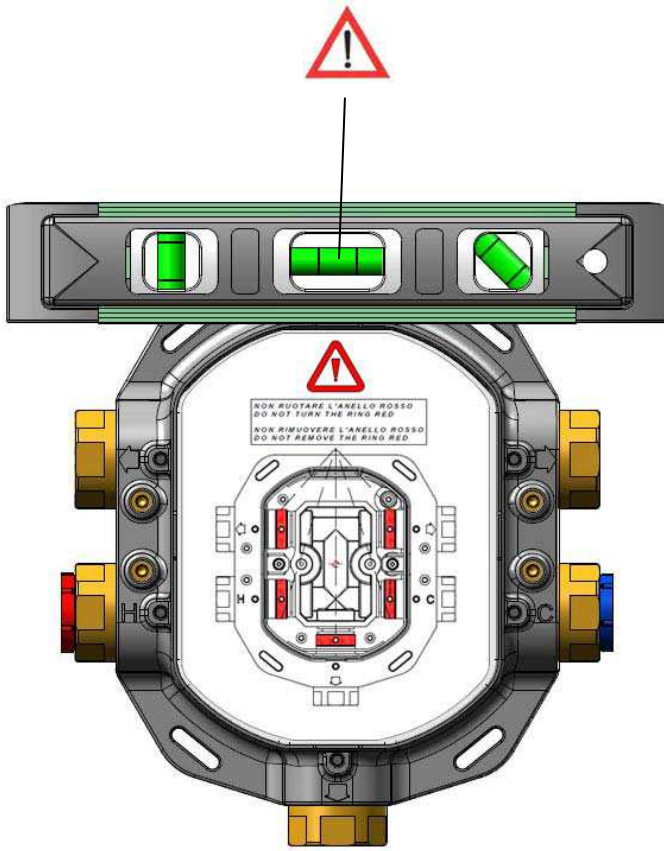

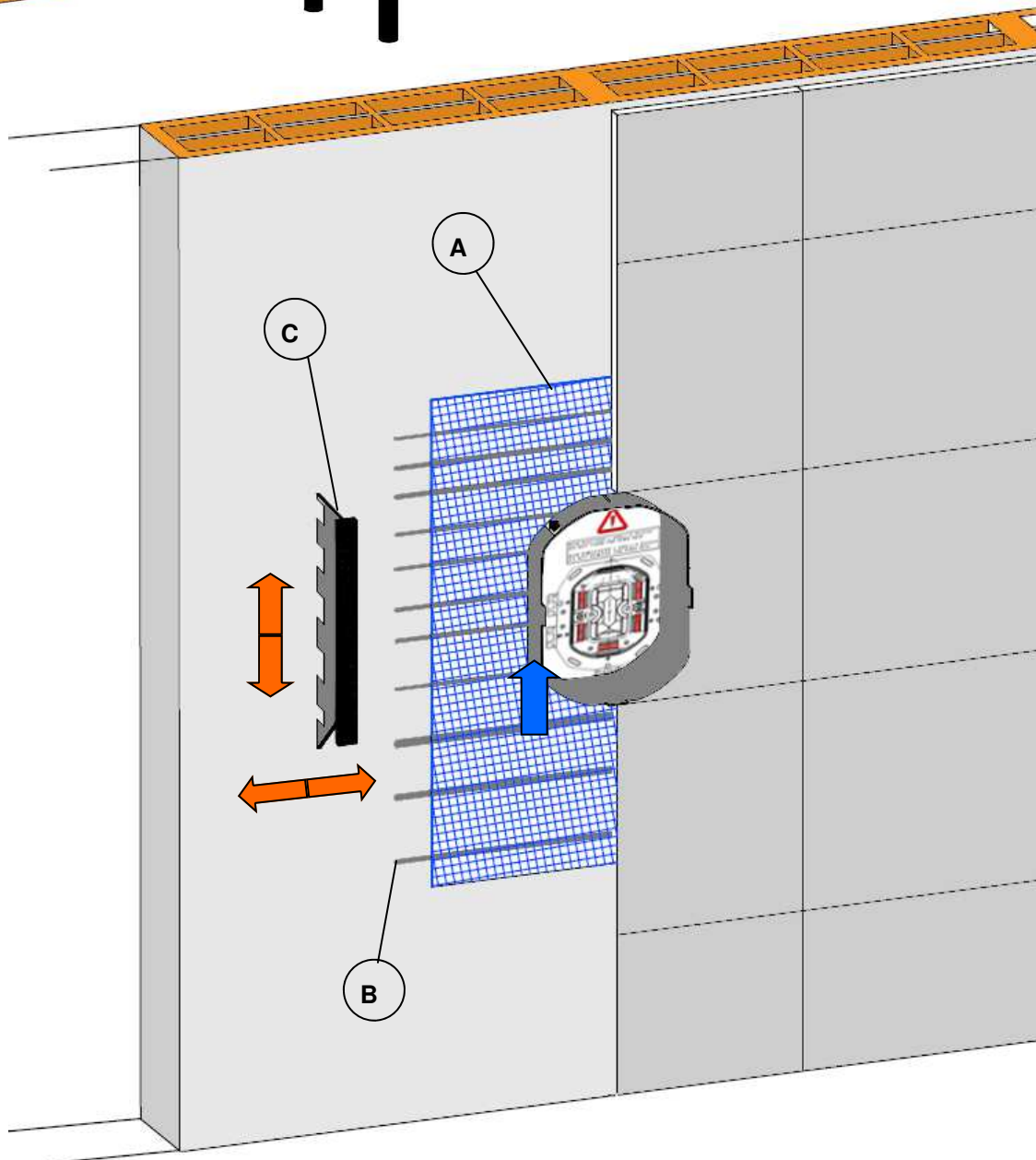
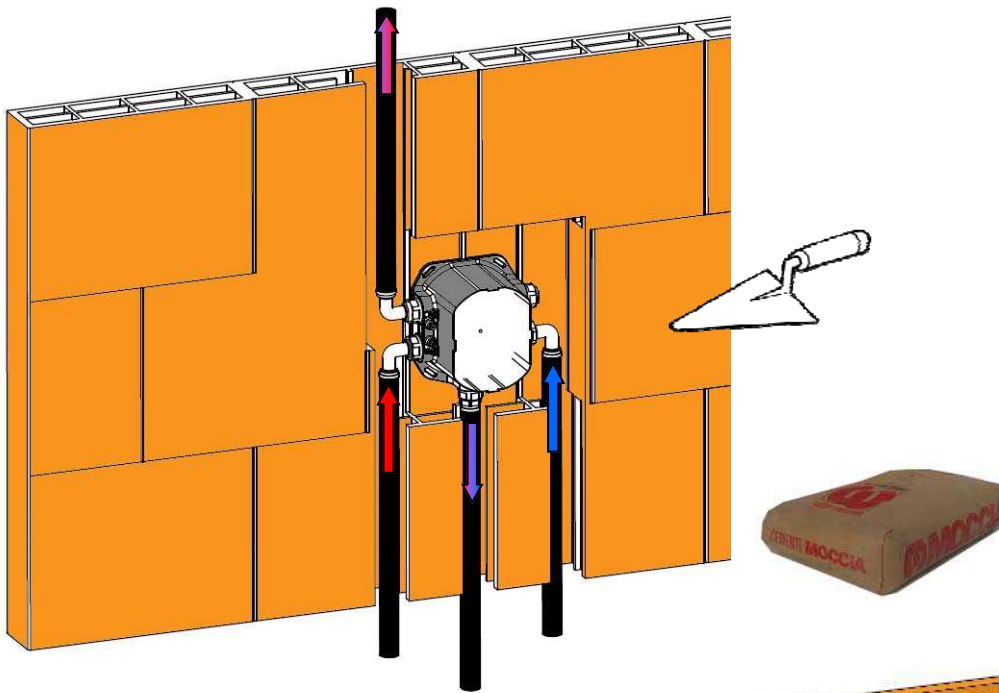

installazione per Cartongesso  
 installation for drywall  
 Installation für den Trockenbau  
 installation de plaques de plâtre

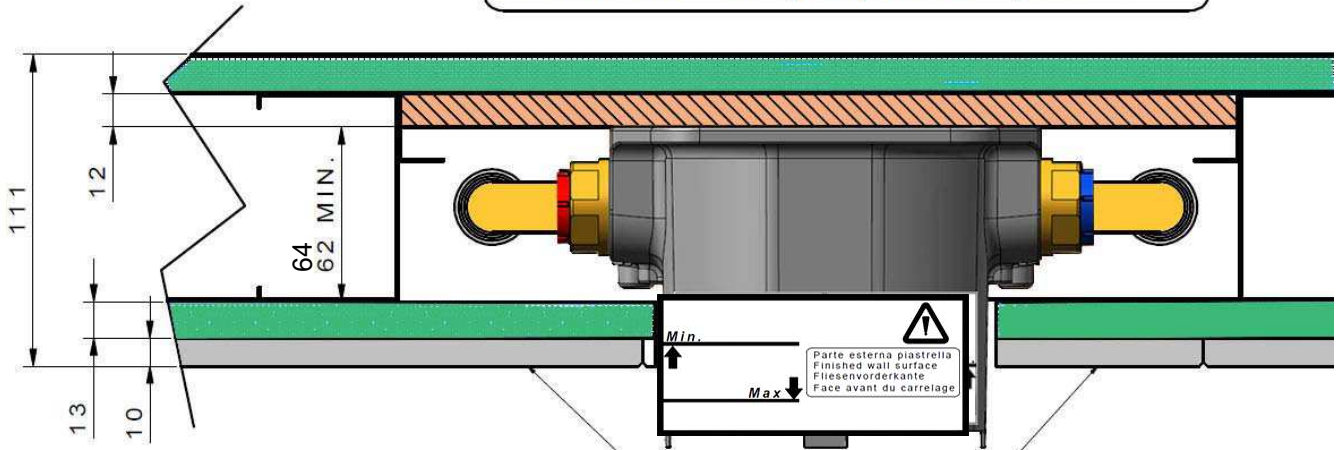

Parte esterna piastrella  
 Finished wall surface  
 Fliesenvorderkante  
 Face avant du carrelage

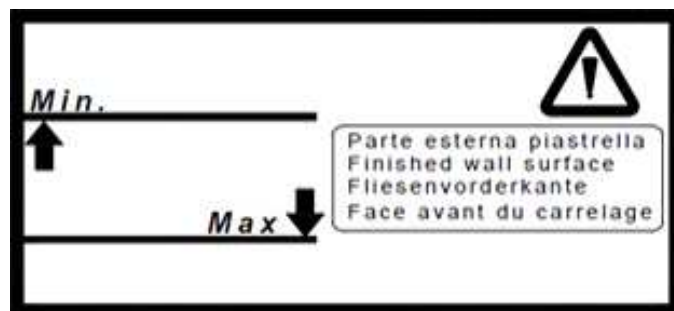
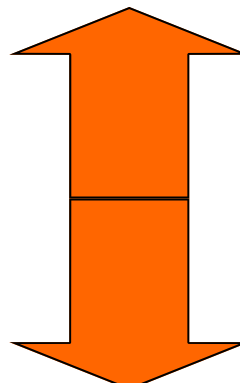

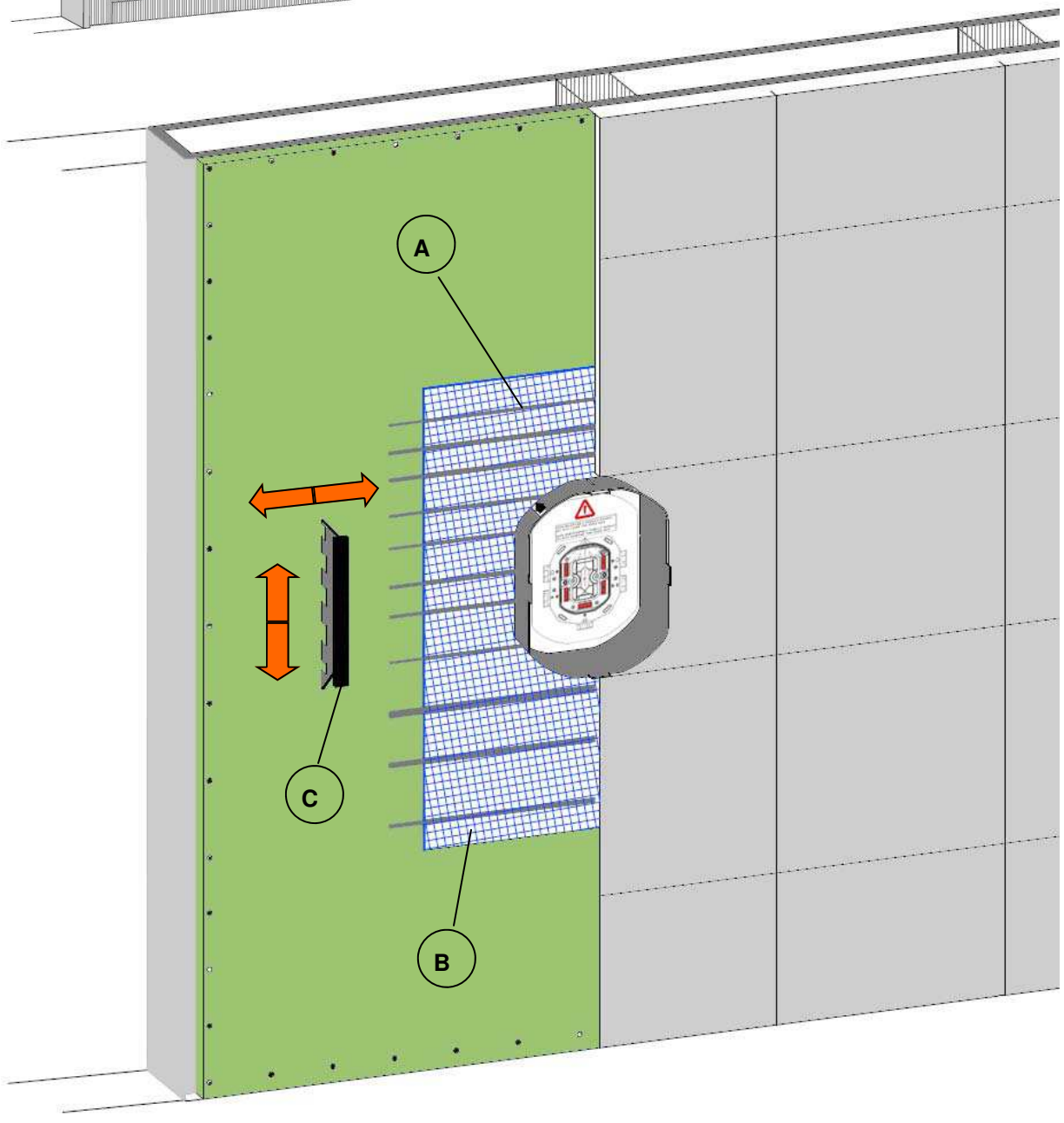
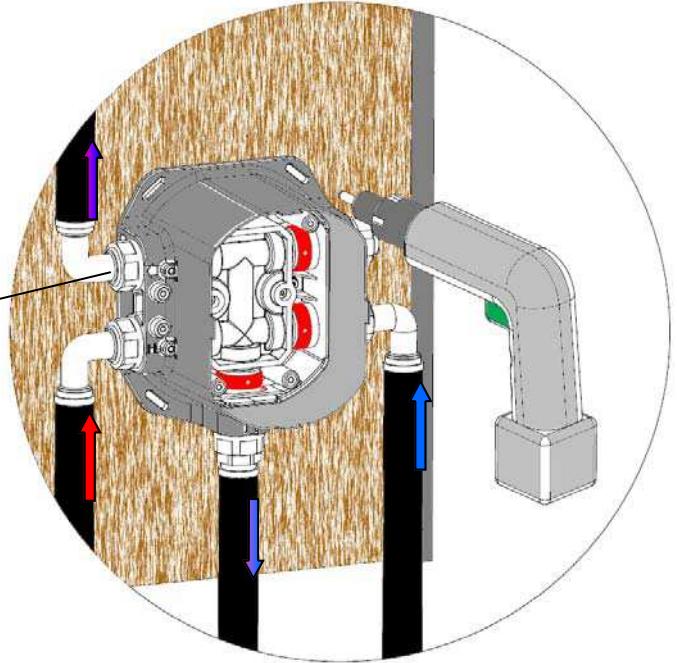
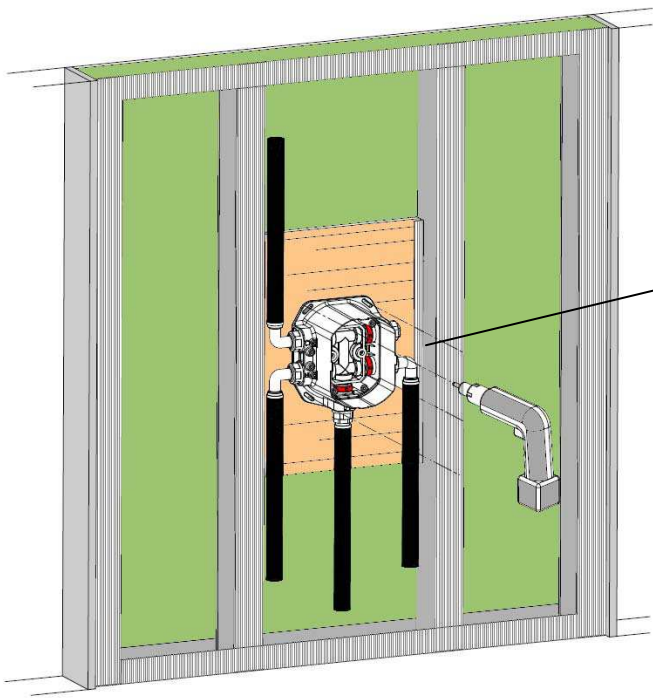

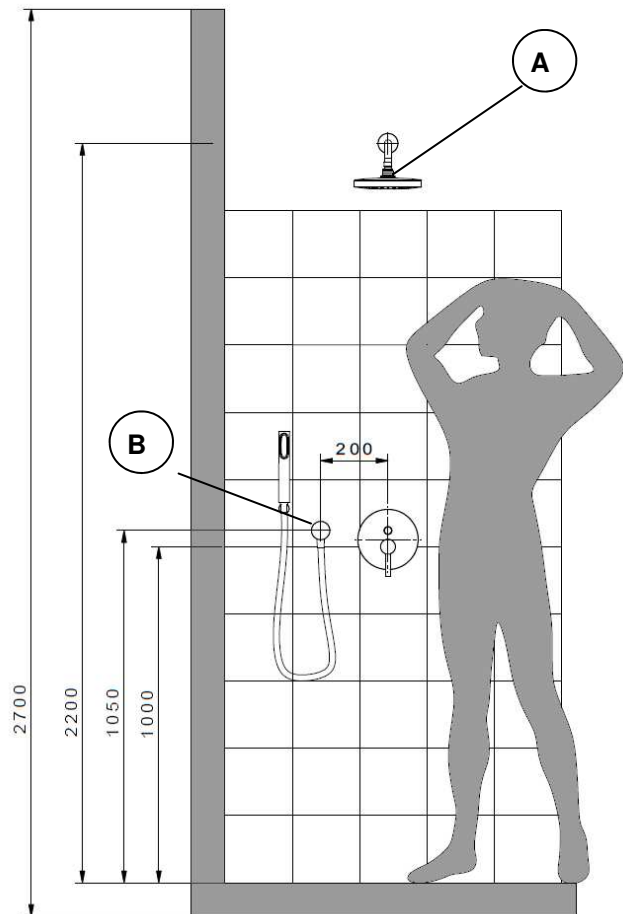
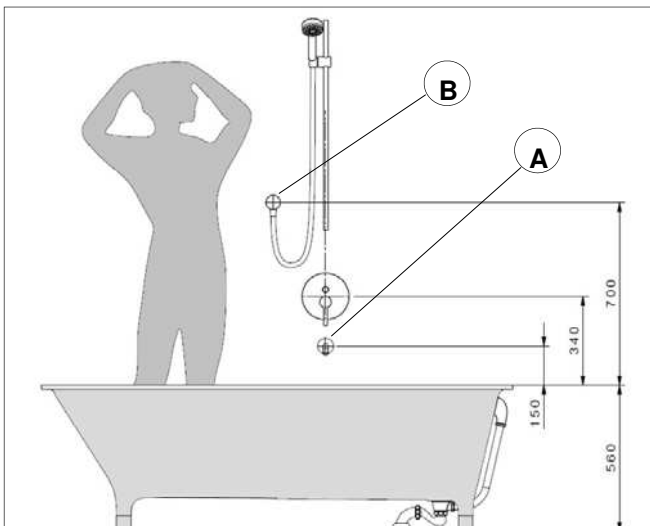
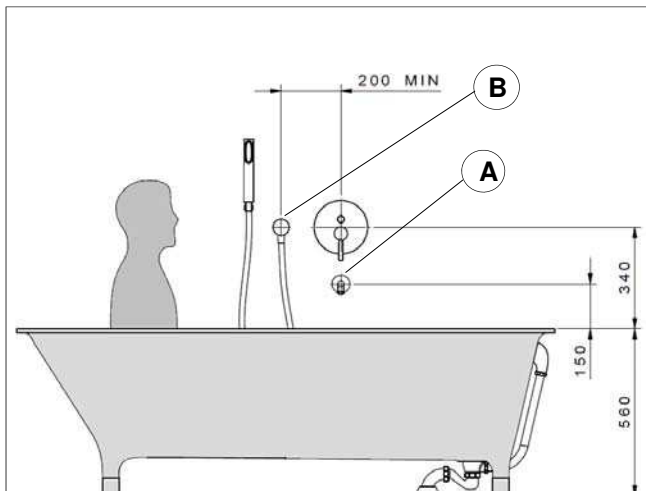

Flowrate (l/min)										
main outlet (A)										
0,5	0,7	0,8	1	2	2,5	3	4	5		Bar
6,5	8,0	8,5	10,5	15,4	18,5	20,0	23,5	26,5	HOT	L/min.
6,5	8,0	8,5	10,5	15,4	18,5	20,0	23,5	26,5	COLD	L/min.
7,5	9,5	10,2	11,7	17,6	19,9	22,0	25,8	28,8	MIX	L/min.

Flowrate (l/min)										
Secondary outlet (B)										
0,5	0,7	0,8	1	2	2,5	3	4	5		Bar
						19,8			HOT	L/min.
						19,8			COLD	L/min.
						21,7			MIX	L/min.

NB. PORTATE IN SCARICO LIBERO  
 NB. FLOW WITHOUT RESISTANCE  
 NB. FLUX SANS RÉSISTANCE  
 NB. FLOW ohne Widerstand

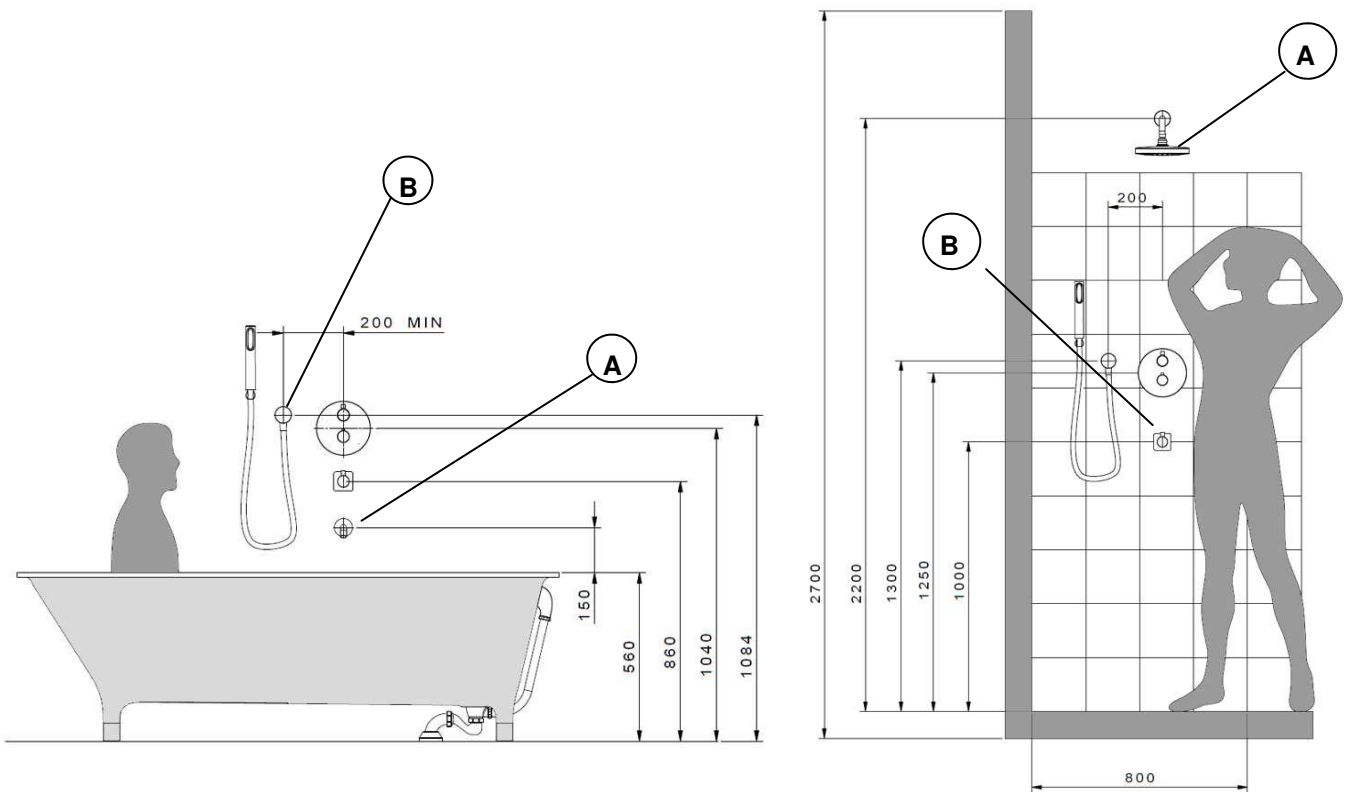

Flowrate (l/min)									
main outlet (A)									
temperature 38°									
				1	2	3	4	5	Bar
				12,0	17,3	21,3	24,5	27,2	L/min.

Flowrate (l/min)									
Secondary outlet (B)									
temperature 38°									
				1	2	3	4	5	Bar
						12,5			L/min.

Flowrate (l/min)									
Secondary outlet (B)									
Pressure 3bar									
				Cold	34°	38°	42°	Hot	°c
				18,4	20,9	21,3	21,6	18,0	L/min.

NB. PORTATE IN SCARICO LIBERO  
 NB. FLOW WITHOUT RESISTANCE  
 NB. FLUX SANS RÉSISTANCE  
 NB. FLOW ohne Widerstand